

Satellite Suites[™]

28' Restroom Trailer

OWNER'S MANUAL



Satellite Suites[™]

Satellite Suites[™]

1686 Commerce Drive, Bristol, Indiana 46507

www.satelliteindustries.com

Table of Contents

28' Restroom Trailer.....	1
OWNER'S MANUAL	1
WELCOME	4
OWNER'S INFORMATION	4
TRANSPORTING YOUR UNIT	5
Towing.....	5
Transporting Your Restroom Trailer.....	6
BEFORE EVENT SET UP CHECKLIST.....	7
AFTER THE EVENT - TEAR DOWN	8
INITIAL SET UP.....	9
Securing the Unit.....	9
Sidewinder Leveling Jack Installation - Two Front/Two Back.....	10
Steps and Grab Handles Set Up.	11
Deploying Steps and Grab Handles.....	11
ELECTRICAL CONNECTIONS.....	13
Power Cords, Outlets and Utility Area.	13
Power Cords.	13
Electrical Outlets.	14
Service Area.....	14
Breaker Boxes	15
Two Cord Operation	Error! Bookmark not defined.
12 Volt Panel Converter.....	16
Fuse Panel	16
Entertainment Center.....	17
Electrical Switches.....	17
Battery Disconnect.....	18
Group 24 - 12 Volt Deep Cycle Battery	18
PLUMBING	19
Water Connections.	19
Pressure Gauge.	19
Water Filter.....	20

City Water Supply - Operating from a Fresh Water Hose Connection.	20
Operating Using On Board Fresh Water Tank System.	21
HVAC - (Heating, Ventilating, and Air Conditioning).....	28
Turning on the Air Conditioning in the Unit.	28
Turning on Heating the Unit.....	29
Optional Forced Air Heat	30
WASTE TANK.....	30
Clean Out Port for Waste Tank.....	30
Banjo Style Valve Dump Valve with a 2" Quick Connect Cam.	31
Deodorizer	31
WINTER OPERATION - ARCTIC PACKAGE.....	32
Waste Tank Heater	32
Waste Tank Heater Circuit Breakers.....	33
Tips When Operating in Inclement Weather.....	33
Dump Valve.....	33
Water Supply.....	33
Skirting the Trailer	33
Monitoring your System.....	33
OPTIONAL - SOLAR PACKAGE	34
FAUCET	22
Adjusting Water Flow.....	23
URINAL.....	25
Adjusting Water Flow.....	25
TROUBLESHOOTING	28
REPAIR PARTS LIST	Error! Bookmark not defined.
CONTACTING CUSTOMER SERVICE.....	36
WINTERIZING	37
GENERAL RESTROOM TRAILER MAINTENANCE TIPS.....	39
WARRANTY	40

WELCOME

Thank you for purchasing a Satellite Suites™ Restroom Trailer. Your trailer is designed to give you many years of service. Of course, the better you care for your trailer the longer your investment will last and the more satisfied your customers will be.

OWNER'S INFORMATION

This owner's manual provides simple and easy to use instructions on how to operate your unit. For additional information, please refer to each individual section for operating procedures. Following are some tips for caring for your unit. If you don't find what you need, please call us at. 574-350-2150 (8 am - 4 pm Monday through Friday).AFTER HOURS CALL 704-287-2065 or 574-596-1626.

A step by step guide on how to set up your trailer for an event and break down after your event is provided on page seven and eight of this manual.



TRANSPORTING YOUR UNIT

We recommend reading "Transporting Your Trailer Checklist" on page six before transporting the trailer to any event. The Satellite Suites™ 28 foot restroom trailer has easy to use front connections for operation and maintenance.



Towing

When towing the restroom trailer it is required that the waste and fresh water tank be pumped and drained to prevent structural damage or unsafe driving conditions. The stairs and hand rails need to be properly secured. When connecting the trailer to a tow vehicle, attach the two safety chains and emergency breakaway cable to the tow vehicle. Then, connect the 7-Pin electrical cord to the vehicle. Notice that the coupler has an open/close pin system. Put the pin in the "close" position to lock the trailer.

For safety, the break-away cable will activate the trailer's emergency brakes if it becomes disconnected from the tow vehicle. The breakaway switch and brakes can be tested at any time to verify the system is functioning properly. To test, simply remove the breakaway lanyard from its position. With the lanyard removed, the trailer brakes should be engaged.



The optional spare tire is mounted on the tongue at the front of the trailer. We recommend to properly secure your spare tire, tighten all lug nuts and check tire pressure to 80 psi before travelling to an event. Always check to be sure the trailer marker lights, tail lights, turn signals, and brake lights are in proper working order. Do not travel on roads without working lights.



Transporting Your Restroom Trailer

Outside the Trailer:

1. Make sure the coupler hitch is in the full locked position on a 2 5/16" ball and pin is in place.
2. Check trailer brakes to make sure they are functional.
3. Make sure breakaway tether is connected from brakes to the truck.
4. Check brake lights, running lights and turn signals to make sure they are operational.
5. Make sure both safety chains are connected.
6. Make sure all steps are in and secure.
7. Make sure handrails are secure.
8. Make sure entry, service, and baggage doors are locked.
9. Make sure all leveling jacks are secure for travel and chains are wrapped around handles in back.
10. Check tire pressure, should be 80 psi.
11. Tighten all lug nuts.
12. Make sure trailer is properly licensed and insured.

Inside Trailer

1. Make sure doors are locked and secure.
2. Trailer clean and free of debris.
3. Close vents.
4. Service area –breakers off, clean.
5. Make sure Waste Tank has been emptied.
6. Make sure Fresh Water Tank has been drained.

BEFORE EVENT SET UP CHECKLIST

1. Level Trailer.
2. Deploy Sidewinder Jacks located on all four corners. Level don't lift.
3. Deploy Folding Steps and Grab Handles.
4. Connect Power Cord to Power Source. (See Electrical)
5. Connect 3/4" Garden Hose to Trailer Water Connection. (See Plumbing)
6. At Service Area, turn on the breakers for the components you'd like to use.
(See Electrical)
7. At Service Area, turn on the components you wish to use.
(See Electrical - AC, Converter, Water Heater, Heater Controls)
- 8a Optional City Fill Operation -At Service Area, Open Bottom City Water Valve and close upper water tank valve.
(Direct fresh water operation.) (See Plumbing for Hose Operation)
- 8b Optional Tank Fill Operation - At Service Area, Close Bottom City Water Valve and open Upper Water Tank Valve. (If Fresh Tank Only.)
9. At Service Area, Turn on Water Pump Switches if using fresh tank. (See Electrical)

Note: For fresh tank operation, see "Operating Using On Board Fresh Water System."

AFTER THE EVENT - TEAR DOWN

After your event has ended the trailer is ready for tear down and transportation home.

1. Pull jacks up and secure with pins for travel.
2. Lock folding steps and grab handles with supplied pins.
3. Shut off all electrical outlets and disconnect cords from power source.
4. Place all cords in storage compartment.
5. Disconnect plumbing from trailer.
6. After centering the trailer over 2 5/16" ball, lower jack until foot is in the air then pull quick release lever and continue until it retracts.
7. Attach coupler until it is in the LOCKED POSITION and insert lock pin.
8. Secure all electrical and plumbing storage compartments and close all vents.
9. Attach two safety chains.
10. Empty fresh water tank.
11. Empty waste tank before transporting.

INITIAL SET UP

Initial set up begins with securing the unit, deploying stairs, plugging in electrical connections and hooking up water lines. See electrical and plumbing sections after initial set up and deploying folding stairs.

Securing the Unit



On site, first unhook from tow vehicle. Position the trailer on as level a surface as possible with the cabin doors facing the event. Always chock the trailer wheels. Position the sidewinder jacks, and use them to level it. Do not lift the tires off the ground. This can be done visually or with a level. Remember leveling the trailer side to side downhill will require you to support the downhill tires with a 2 X 8 boards or similar support.

Do not use the jacks to lift trailer off the ground.

Front of Trailer

Back of Trailer



Side-Winder Jacks (Front)

Side-Winder Jacks (Rear)

The Satellite Suites™ 28 foot trailer has four 7,000 pound side-winder jacks located in the front and back of the unit. This is designed to keep the trailer stable and secure when in use.

Sidewinder Leveling Jack Installation - Two Front/Two Back.

The Satellite Suites™ 28 foot trailer has two side-winder jacks located in the front and back of the unit. We recommend the following step by step instructions before operating the trailer.



Sidewinder Leveling Jack



1. Remove Keeper Pin then rotate 90°



2. Insert Keeper Pin.



3. Remove Quick Adjust Pin.



4. Adjust Height and Insert Pin.



5. Once in contact with the ground rotate three to five times.

Steps and Grab Handles Set Up.

The Satellite Suites™ 28 foot restroom trailer has two fold down steps located at the side of the unit. The following is a step by step guide on how to install and operate fold down steps and door handles before your unit is operational.

Deploying Steps and Grab Handles.



Deploying Steps.

1. Pull Spring Loaded Pin To Out Position.



2. Pull Steps Out and Lock in Place With Spring Loaded Pins

3. Lift Support Bracket Up



4. Lift Bracket and Pull Steps towards Trailer until Pin is Inserted into Lock Hole on Step Frame.

The Support Bracket Must Lock in Place to Properly Secure the Steps for Use.



5. Pull Down Right Front Stair Jack.



6. Pull Down Left Front Stair Jack.



7. Add Tension with Service Area Bar.



8. Add Tension with Service Area Bar.



9. Fold Down Bottom Step.



10. Apply pressure to secure stairs.



11. Remove Door Handle Pin.



12. Install Door Handle Pin.

ELECTRICAL CONNECTIONS

To operate the system after trailer is leveled, stairs deployed, water connections are installed, all electrical connections must be connected before operating the trailer.



Cord Storage



Power Cords



Electrical Outlets

Power Cords, Outlets and Utility Area.

Select power cord from storage compartment and plug into the electrical outlet on the trailer, then connect the cord to a power source. If the unit has power, it will show a blue light on the cord and at the cord connection at the trailer. If blue light is not present then check power connections to see if plugged in and the power supply is on. The power cord can be used with a twist lock connection to the generator or with an adapter to use in a standard outlet with 20 amps available.

THE CORD IS 30 AMP TWIST-LOCK STYLE, BUT WILL NOT DRAW MORE THAN 20 AMPS.



Check Blue Light on Cord



Check Blue Light on Trailer

Power Cords.

28' Trailer Power Cords

Cord 1 – Main Breaker, Converter, Women's AC, Women's Heat - 20 Amps Max

Cord 2 – Main Breaker, Water Heater, Service Area Recept - 20 Amps Max

Cord 3 – Main Breaker, Men's AC, Men's Heater - 20 Amps Max

Cord 4 – Main Breaker, Service Area Heater, Waste Tank Heater, Waste Tank Heater – 20 Amps Max

The Satellite Suites™ 28 foot restroom trailer includes four easy to use power cords. Trailers come equipped with one 28' 10-gauge cord, with twist-lock connection and standard outlet adapter PER breaker box. The 28' trailer can operate from two 20-Amp services (including ACs, lights, water pump, vents, entertainment package). A third cord is required for the optional water heater and the fourth cord for the optional forced air heat. All breakers are designed to draw no more than 20 Amps each. When running cords longer than 28', use 10 gauge extension cord. No more than 100'.

Electrical Outlets.

The Satellite Suites™ 28 foot restroom trailer has two to four easy to use electrical outlets. We suggest running all electrical cords after connecting thru the easy to use drop down access port.



1. Electrical Outlets



2. Easy to Use Drop Down Access.

Service Area



The Satellite Suites™ 28 foot trailer service area is located at the side of the unit, The trailer has easy access to electrical, plumbing, and auxiliary controls. The following sections will assist you in troubleshooting your trailer if a problem occurs.

The service area has easy access to circuit breakers, fuses, 12 volt converter, battery disconnect, lights, vents, entertainment center, and master water pump.

Breaker Boxes



The Satellite Suites™ 28 foot restroom trailer has two to four breaker boxes located in the service area. We suggest checking all breakers you select are in the on position before operation..



Breaker One



Breaker Two



Breaker Three



Breaker Four

Breaker Box 1 Main Breaker, Converter, Women's AC, Women's Heat - 20 Amps Max

Breaker Box 2 Main Breaker, Water Heater, Service Area Recept - 20 Amps Max

Breaker Box 3 Main Breaker, Men's AC, Men's Heater - 20 Amps Max

Breaker Box 4 Main Breaker, Service Area Heater, Waste Tank Heater, Waste Tank Heater – 20 Amps Max

Note: Breaker Box 4 is used during fall and winter for heating the waste tank and service area only.

12 Volt Panel Converter



12 Volt Panel - Converter



12 Volt Panel



Converter

The Satellite Suites™ 28 foot restroom includes a 12 Volt Panel located in the service area. This is the main control center for your Fuses, AM/FM Radio/Bluetooth Entertainment Center, Men's lights, Women's Lights, Exterior Lights, Service Area Light, Master Water Pump, Men's Vents and Women's Vents Switches and Battery Disconnect.

Fuse Panel

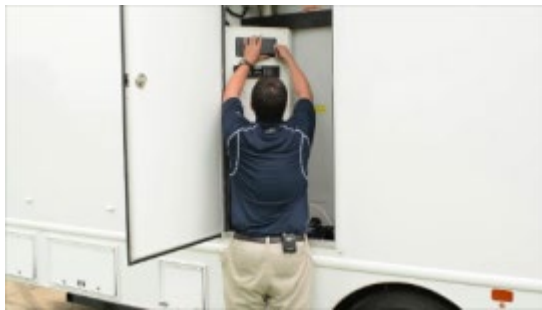

Removing Fuse Panel

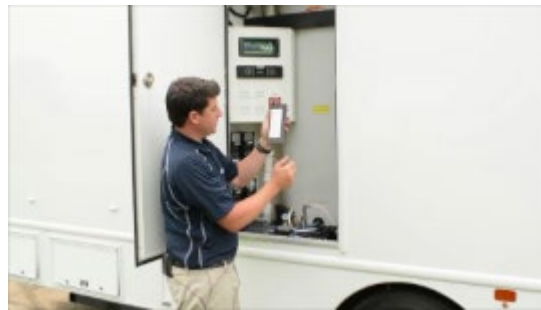

Fuse panel

The fuse panel is located at the top of the 12 Volt Converter in the Service Area. Remove fuse panel with key or coin, open compartment, check and replace fuses.

Fuses - All 15 amp

1. Men's Lights
2. Women's Lights
3. Porch Lights
4. Women's Vent
5. Men's Vent
6. Service Area Light
7. Pump One
8. Pump Two
9. Radio
10. Optional Waste Tank Heater

Entertainment Center



Entertainment Center



Bluetooth & Code

The Satellite Suites™ 28 foot restroom trailer includes AM/FM Radio and Bluetooth technology. Music can be played from your Bluetooth capable mobile device or the event planners phone by entering the 0000 code.

Electrical Switches

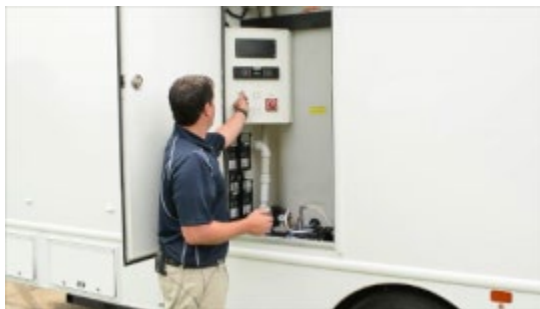

12 Volt Switches in Unit



12 Volt Switches

The Satellite Suites™ 28 foot restroom trailer includes eight panel switches to operate various lights, water pumps, and vent fans.

1. Men's lights, Women's Lights
2. Exterior lights, Service Area
3. Pump One, Pump Two
4. Men's Vents, Women's Vents

Battery Disconnect



Battery Disconnect in unit



Disconnect Panel

Battery Disconnect allows power to flow from the battery. Interior and Exterior lights at night can be operated by turning the battery disconnect to the on position. At night the delivery driver can turn on lights for easy set up.

If you lose power the battery disconnect can be turned on to provide lights, water and vents but air conditioning and heat will not be available.

Note: The battery disconnect switch must be in the on position and the converter plugged in for the system to charge.



Group 24 - 12 Volt Deep Cycle Battery

A group 24- 12 volt deep cycle battery is included mounted on the frame tongue at the front of the unit. The main purpose of the group 24- 12 volt battery is to provide emergency braking should the trailer become disconnected from your tow vehicle. The secondary feature of the battery is to provide auxiliary power to run the lights, vents, water and entertainment center for a limited time.

PLUMBING

Water Connections.

To operate the system after trailer is leveled and stairs deployed, connect a 3/4" garden hose to the trailer's water connection. The trailer comes standard with a pressure regulator that cuts pressure to 40 psi. If no water is available the system can be operated by using the on-board fresh water tank.



1. Water Connection Port.

2. 3/4" Water Connection

Note: It is recommended to use 40-60 psi during operation. If the water pressure is above the recommended 40-60 psi your unit can overpower your fixtures inside the trailer. Golf Courses or municipal water systems normally have higher pressure. (100 psi.)

Pressure Gauge.

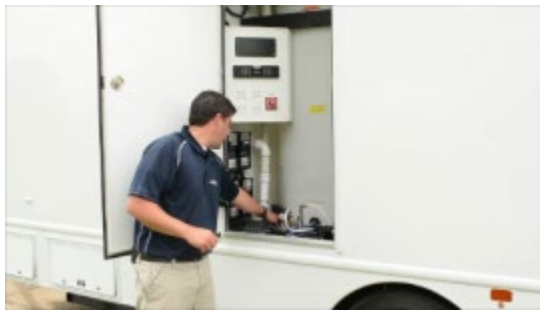

Pressure Gauge in Unit.

Pressure Gauge

When water connections are connected to the trailer the pressure regulator will reduce the water flow to 40psi. It is recommended to check the pressure gauge before operation. If the pressure gauge indicates more than 60 psi reduce the water pressure at the source.



Water Filter

The unit is equipped with a water filter. Check and clean the water filter periodically every 30-60 days

City Water Supply - Operating from a Fresh Water Hose Connection.

The trailer is designed to operate using standard city water. Once the 3/4" is connected, at the service area, open the bottom city water valve and close the upper water tank valve to operate. Do not use the water pump valve or switch since the fresh water connection will provide pressure to the system.

At Service Area:



1. Open city water supply valve.



2. Close water tank fill valve.



Operating Using On Board Fresh Water Tank System.

If city water is not available, the Satellite Suites™ 28 foot trailer is equipped with an on board fresh water tank. To fill the fresh water tank, close the bottom city water valve and open the upper water tank valve. Once the tank is full, shut off hose and disconnect from trailer. Open the pump supply valve coming from the bottom of the tank. It is located before and after the 12 volt master pump. Turn on the 12 volt pump switch to automatically pressurize the system. During use, pump will turn on/off as needed. Should pump run continuously see troubleshooting section.

Note: Be sure to fill the fresh tank on site. Do not transport with fresh tank full.

At Service Area:



1. Close city water valve.



2. Open water tank valve.



The water tank must be emptied after the event is over. Open the 1 1/2" shut off valve to drain tank after the event is over. Do not transport the trailer with a filled water tank.

Optional Water Heater

The trailer has one on board water heater. The water heater must be full of water and all air must be out of the system before electric is turned on. Before turning power on tank must be full of water if this not accomplished the water heater element could be damaged. Turn on the water heater, plug in the water heaters into the receptacle and turn on the water heater breaker in the service area.



Plug in Water Heater



Brass Pop Off

Low Point

Note: Low point clockwise to close and counter-clockwise to drain.

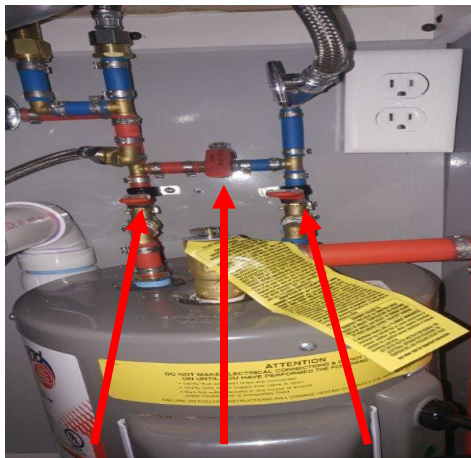

Inlet

Bypass

Outlet

Inlet and Outlet valves are open. By Pass valve is closed to operate water heater.

FAUCET

Adjusting Water Flow

If water continues to run too long or short, the faucet cartridge can be adjusted for more or less water flow. **Always shut the water off before repairing the faucet. The water shut off valve located at the water port at the side of the trailer.**



1. Remove Cover Plate



2. Remove Fastener



3. Remove Cartridge



4. Adjust Cartridge by Loosening Hex Nut.

Adjust the cartridge counter-clockwise to increase and clockwise to reduce water flow. Be sure to reverse your steps and reinstall the cartridge.

Be sure to reverse your steps and reinstall the cartridge.



Dis Assembled Aerator.



Cleaned Aerator Assembled



Aerator

The sink aerator will need periodic cleaning to increase your water flow. After maintenance is completed be sure to turn the water in your unit back on.

FAUCET DIAGRAM

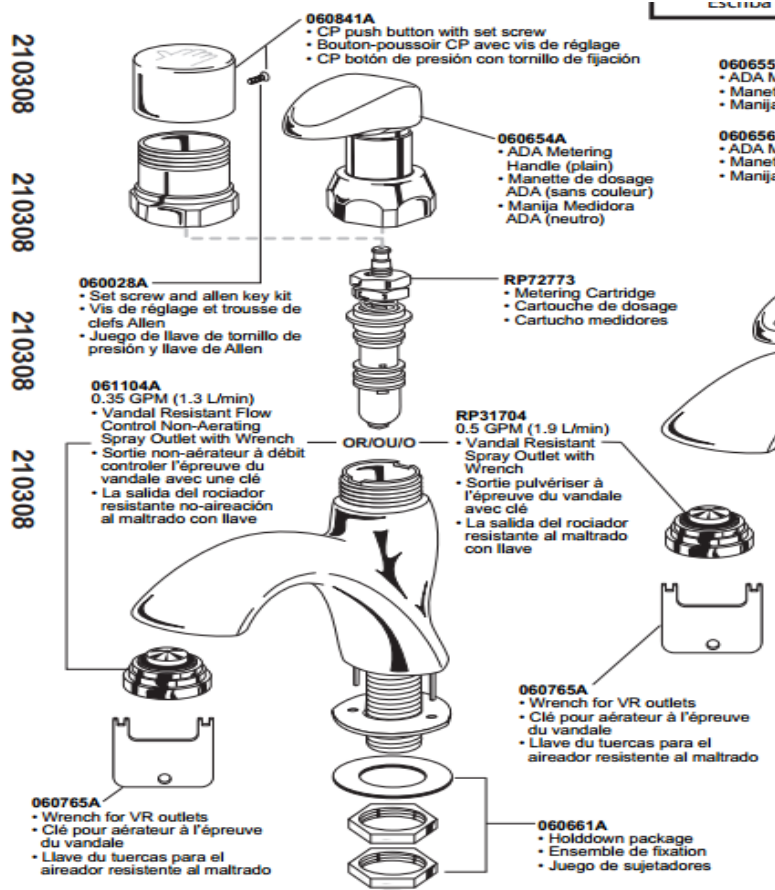

50045	87T105	FAUCET METERED CHROME
-------	--------	-----------------------

Satellite Part

#	Delta Part #	Description
51002	RP72773	Metering Cartridge
51276	RP31704	FAUCET .5 GPM AERATOR KIT

URINAL

Adjusting Water Flow

If water continues to run too long or too short, the flush valve cartridge can be adjusted for more or less water flow. Always close urinal shut off valve and turn water off before repairing.



1. Urinal

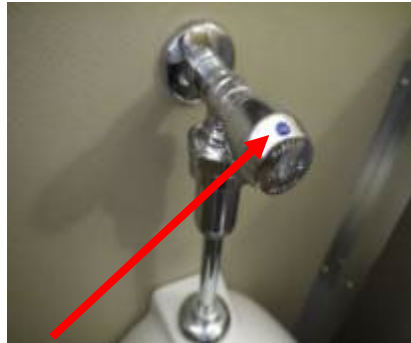

2. Remove Cap and Screw



3. Remove Cartridge



4. Adjust Water Flow

Adjust the cartridge counter-clockwise to decrease water flow and clockwise to increase water flow. Be sure to reverse your steps and reinstall the cartridge.

The urinal flush valve cartridge will need periodic cleaning to increase your water flow. After maintenance turn the water on in the unit. The Urinal shut off valve is located in the water connection port.



Location of Urinal Shut Off Valve in Service Area.

URINAL VALVE DIAGRAM

PARTS LIST	BY: SID		FINISH: AS SPECIFIED
	CHK'D:		DATE: 10-17-03
732-VB665PSH			REV: 04-02-07

ITEM NO.	PART NO.	DESCRIPTION	ITEM NO.	PART NO.	DESCRIPTION
1	665-PSH	HANDLE PUSH BUTTON ASSEMBLY	8	-----	VALVE BODY (NOT SOLD SEPARATELY)
2	665-116	SET SCREW	9	749-016	WALL FLANGE
3	665-309K	BUTTONS, HOT AND COLD	10	734-005	GASKET
4	665-190K	ACTUATOR ASSEMBLY	11	734-001	ADAPTER
5	665-011	SEALING WASHER	12	734-105K	URINAL V.B. REPAIR KIT
6	671-X	METERING VALVE CARTRIDGE	13	734	URINAL VALVE VACUUM BREAKER
7	667-402	FILTER	14	142-PP	FLANGE ASSEMBLY PRE-PACK

50046	41N754	URINAL VALVE COMPLETE
-------	--------	-----------------------

drawing #	Satellite Part #	Chicago Part #	Description
6	51002	RP72773	Metering Cartridge
13	51276	RP31704	FAUCET .5 GPM AERATOR KIT

TOILET DIAGRAM

Aqua Magic® Style II

Part Diagram

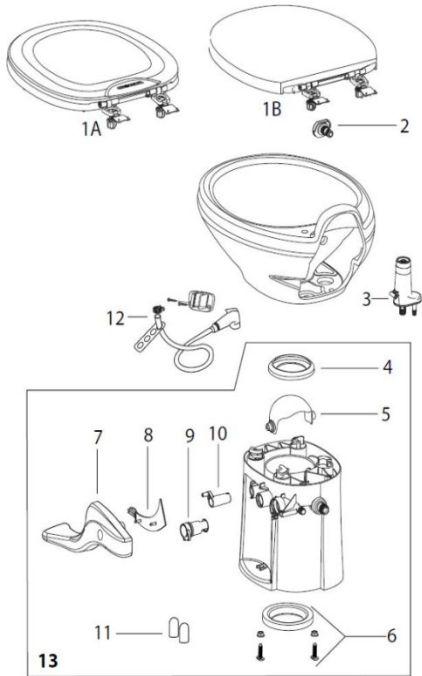

Key No.	Part No.	Description
1A	42036	Seat and Cover Assembly - White (pre-May 2015)
1A	42037	Seat and Cover Assembly - Bone (pre-May 2015)
1B	42178	Seat and Cover Assembly - White (post-May 2015)
1B	42179	Seat and Cover Assembly - Bone (post-May 2015)
2	34124	Nozzle - White
	34125	Nozzle - Bone
3	34122	Vacuum Breaker
4	42141	Waste Ball Seal
5	34117	Waste Ball - White
6	42115	Closet Bolt Package
7	42067	Pedal - High - White
	42068	Pedal - High - Bone
	42078	Pedal - Low - White
	42079	Pedal - Low - Bone
8	42080	Pedal Cover Insert - White
	42081	Pedal Cover Insert - Bone
9	42049	Water Valve
10	42048	Waste Ball Drive Arm
11	42111	Bolt Caps - White
	42112	Bolt Caps - Bone
12	19289	Chrome Hand Spray Kit (Water Saver Option Only)
13	42135	Base - Low White
	42137	Base - High White
	42136	Base - Low Bone
	42138	Base - High Bone

50406		42201	TOILET STILE II HG WHITE
-------	--	-------	--------------------------

Satellite Part #	Key No.	Thetford Part #	Description
50752	1B	42178	Seat and Cover Assembly
	2	34124	Nozzle
51853	3	34122	Vacuum Breaker
50715	4	42141	Waste Ball Seal
50839	5	34117	Waste Ball
50712	6	42115	Closet Bolt Package
51630	7	42067	Pedal
	8	42080	Pedal Cover Insert-White
50714	9	42049	Water Valve
51421	10	42048	Waste Ball Arm
	11	42111	Bolt Cap-White
50219	13	42135	Base-Lower White

HVAC - (Heating, Ventilating, and Air Conditioning)

Turning on the Air Conditioning in the Unit.

Turn on air conditioning at the control panel to cool. The setting must be colder than the inside temperature to operate. The AC/Heating Unit has retractable air vents, easy to use controls and pop off vent screen for easy cleaning.



AC/Heat Unit



Open Air Vents



Turn On Controls



Clean Vent Screen

To operate the air conditioning unit, the main breaker, 20 amp AC breaker and 12 volt converter must be turned on. The main breaker must always be in the on position.



Men's AC Breaker



Women's AC Breaker



12 Volt Converter Panel Switches

Turning on Heating the Unit.

Turn on Heater at the control panel to warm and open vents. If the outside temperature is between 45-50 ° the standard use heat strip located in the AC unit will provide heat.

Note: An optional 4 Star Heat unit is also available.



AC/Heat Unit



Open Air Vents



Turn On Controls



Clean Vent Screen

To operate the heating unit the proper circuit breakers, thermostat and the 12 volt convertor must also be in the on position to operate.



Men's Heater



Women's Heater

The user has several options to turn on each corresponding breaker boxes in which they intend to use. The main breaker must be in the on position always.

Optional Forced Air Heat



Forced Air Control



Service Area Heater

Optional forced air heat is located beneath the vanity. The main breaker and appropriate (men's/women's) switch must be in the on position. Use the forced air heat when the outside temperature is below 50 ° Fahrenheit.

WASTE TANK

Clean Out Port for Waste Tank.



Rear of Trailer.



Open Access Door



Accessible 4" Clean Out Port.

The Satellite Suites™ 28 foot trailer has an easy to use 4" clean out port for your waste tank. We use a smooth polypropylene tank so waste won't stick to it, and added a low point sump with bottom dump so you get all the waste out when the unit is pumped. We suggested using a power washer to clean out the tank occasionally.

Banjo Style Valve Dump Valve with a 2" Quick Connect Cam.



Front of Trailer

The unit includes a banjo style valve dump valve with a 2" quick connect cam. The banjo valve dumps from the bottom of the waste tank with a low point sump. Connect vacuum hose to 2" quick connect cam to dispose waste. Do not empty into a local sewer.

1. Check site gauge located near the water inlet to determine if the tank needs to be pumped. ALWAYS pump the tank before transport.
2. Lower Tongue Jack so contents flows to the front of the unit.
3. Connect vacuum hose to 2" quick connect cam located in the front of the trailer in the protected area inside the tongue.
4. Open valve.
5. Vacuum waste from tank.
6. Add water deodorizers to bathroom toilets.

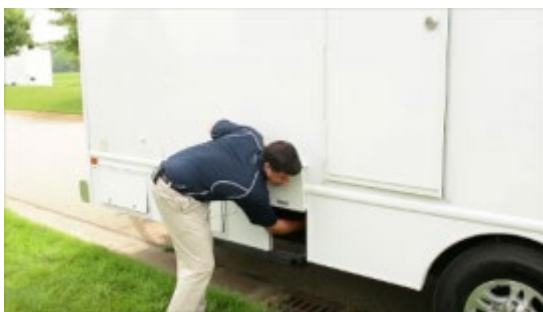

The Waste Site Gauge is located near the service area at the water inlet. To prevent overfilling, the waste tank should be emptied when the gauge show no more than 75% full.

Deodorizer

Either at the shop prior to delivery, or at the customer site, prep the tank with Safe-T-Fresh™ QuickScents™ Bio packets. Dissolve and disperse 6 to 8 packets with 10% of tank volume to the waste tank through one of the toilets. Ideally, the units should be prepped after each event and will be ready to go for the next event.

WINTER OPERATION - ARCTIC PACKAGE



Heat Pads



Foam Insulation



Underbelly



Insulated Tank

If your trailer is equipped with the optional Arctic Package, when temperatures approach freezing, the Arctic Package will provide electric forced air heat to the cabin, service area, waste tank insulation and 110 volt waste tank heat pads. The Arctic Package is operated during fall and winter months for heating the waste tank, service area and interior cabin.

To operate the Arctic Package:

1. Plug in all electrical cords (20 amp max.) into all receptacles (1,2,3,4).
2. Turn on all electrical breakers. (except Men's and Women's AC)
3. Turn on cabin heat below vanity and adjust thermostat in the service area.
4. Turn on circuit breaker switch for heat pads.

Waste Tank Heater



Heat Pads



Insulated Tank

The Arctic Package provides protection from inclement weather. Frigid temperatures can cause freezing of your waste tank. It includes switches to turn on the unit at 35° and off at 45° Fahrenheit. The trailer is installed with 110v heater/heat pads for waste water heat. A 12 volt thermostat located in the service area and optional forced air heat in the cabin will provide heat.

Waste Tank Heater Circuit Breakers



Main/Waste Tank Heat/Service Room Heat (Breaker Four)

If your trailer is equipped with the optional Arctic Package, it will have four breaker boxes located in the Service Area. Turn on the Main/Waste Tank Heat/Service Room Heat Breakers to operate the heat. To operate the waste tank heater all breakers must be in the on position.

Tips When Operating in Inclement Weather

We suggest the following tips when operating in inclement weather.

Dump Valve

Ice and snow can prevent your dump valve from operating efficiently. Clear all ice and snow away from the valve before using. The dump valve should be insulated with heat trace to prevent freezing.

Water Supply

Ice and snow can freeze your water supply lines and prevent you from operating efficiently. Clear all ice and snow away from the 3/4" water valve before using. Check your water supply source to make sure it is clear and flowing before operating. Supply lines should be insulated with heat trace to prevent freezing.

Skirting the Trailer

Protecting your trailer from the inclement weather is essential to ensuring years of use. Skirting the trailer will prevent cold air from circulating underneath and will reduce the chance of freezing when the temperature is freezing.

Monitoring your System

We recommend monitoring the water and heating system often. This will ensure your trailer will not require maintenance or replacement parts due to winter operation.

OPTIONAL - SOLAR PACKAGE



12 Volt Converter
Switches



Solar Controls



Solar Panel (Roof)



Batteries (2)

If your trailer is equipped with an optional solar package, it will have a solar panel mounted on the roof, Group 31 12-Volt batteries, and a Solar Controller. The solar panel will charge the batteries when it is exposed to daylight. The batteries will then power the 12-volt items on the trailer, which are lights, vents, water pump(s), and the entertainment package. The solar package WILL NOT power the air conditioner, heaters, or water heater. With properly charged batteries, the trailer can operate its basic functions free from a dedicated power source for a limited amount of time.

1. Always start an event with fully charged batteries. To do this make sure the breaker with the converter is plugged in and that converter switch is in the ON position. Also make sure the RED battery switch is in the ON position. With the converter plugged in and turned on, allow the batteries to charge at least over night.
2. Once at the event, make sure the RED battery switch is in the ON position. Then turn on the components that you'd like to run from the Solar package (lights, water pump(s), vents, entertainment package).
3. The Solar Controller digital readout will let you know how much power is being supplied by the solar panel. In normal conditions, it should read in the range from 12.0 to 14.0. If it is significantly less than that, clean the solar panel.
4. Depending on usage, the solar package should deliver 8 to 24 hours usage free from a power source.

When the trailer is not in use, turn the RED battery switch to the OFF position. The solar panel will continue to charge the batteries, and keep them charged. Periodically clean the solar panel for maximum performance. It is located on the roof. Be sure to use the proper safety equipment to access it.

TROUBLESHOOTING

Problem

Solution

I don't have water.

Check water connections.

Check water source.

Check water shut off valves.

I don't have power.

Check power cord for blue light.

Check power connections.

Trailer has to be grounded.

Jacks must be touching the ground.

Check main breaker is on.

Air Conditioning does not work.

Check power source.

Check AC breakers are on. (Men & Women)

Check power connections & main breaker.

Check thermostat is on.

Check converter breaker is on.

Vents do not work.

Check main breaker is on.

Check vent switch on converter is on.

Check power source.

Check 12 volt fuse.

Lights do not work

Check main breaker is on.

Check lights switch on converter is on.

Turn on Battery Disconnect (auxiliary power).

Check power source.

Check 15 amp fuse.

Faucets run too long or short

Adjust Sink Cartridge.

Urinals run too long or short.

Adjust or replace the urinal flush valve cartridge.

Toilets won't stop running.

Close shut off valve behind toilet.

Replace base.

CONTACTING CUSTOMER SERVICE

CALL THE MAIN BUSINESS OFFICE AT 574-350-2150 FROM 8 AM -4 PM EASTERN TIME ZONE. AFTER HOURS CALL 704-287-2065 or 574-596-1626

WINTERIZING



As temperatures fall below freezing your Satellite Suites trailer will need to be winterized, unless it is in operation and equipped with the Arctic Package (see accessories). All water must be removed from the trailer or be treated with RV Antifreeze (propylene glycol). RV Antifreeze is environmentally safe and therefore the only antifreeze recommended for winterizing the trailer.

Failing to follow the winterization process instructions below will likely result in costly repairs to the trailer.

There are two methods to winterize your trailer. One method is to use compressed air and a minimal amount of RV Antifreeze. The other method is to pump RV Antifreeze throughout your entire water/plumbing system.

Winterizing with Compressed Air – To use this method you will need an air compressor and air hose with a $\frac{3}{4}$ inch treaded hose fitting at the end to connect to the water intake valve on the trailer. If your air hose does not have a $\frac{3}{4}$ inch threaded fitting on the end, remove one from the end of a garden hose and attach it with a hose clamp. An operator should run a small amount of RV antifreeze through his pump(s), since even running dry still leaves some water inside the plumbing and tanks. To begin winterizing your trailer, drain the trailer's fresh water tank, water heater and water pump. There is a drain on both the fresh water tank and water heater. **NOTE: Some trailers do not have water heaters and therefore, do not need servicing.** Next, run the water pump until it is dry but stop immediately after. The system is now ready to be cleared using compressed air. Start by connecting the air compressor to the water intake valve on the side of your trailer. Next, open the Fill Valve on the freshwater tank. Turn on the compressed air and clear the line. Close the Fill Valve when finished. Next, open the City Fill Valve and turn on the compressed air. With the compressed air on, begin opening each of the toilet and water fixtures in the trailer, beginning with the one furthest away from the air supply and working back towards the air source. Flush each toilet and urinal until there is only air escaping. Turn off the air compressor when toilets and urinals are clear.

Next, make sure the ball valve on the toilet is closed and add a few ounces of RV Antifreeze. For the urinals, pour in 16 ounces of RV Antifreeze in each urinal.

The trailer's water system is now clear and ready for storage.

Winterizing using RV Antifreeze – To winterize using this method you will need an on-board water pump or external 12 volt pump along with a clear antifreeze supply hose. For trailers with a water heater, use the water heater drain and empty the unit. Now, open the bypass valve. This prevents antifreeze from flowing into the water heater.

The next step is to use the clear hose and connect it to the intake of the water pump. Once complete, put the end of the clear hose into a gallon of RV Antifreeze. Turn on the pump to begin pumping antifreeze into the system.

Starting at the fixture furthest from the water pump, open the fixture and run until only pure antifreeze is visible. Do this for each toilet, sink and urinal.

Also, if you are using an on-board pump to distribute the antifreeze, be sure to open the City Fill Valve and External Shut-Off Valve at the City Water Connection. Run until pure antifreeze is visible.



GENERAL RESTROOM TRAILER MAINTENANCE TIPS

Cleaning

The entire trailer can be cleaned with general household cleaners. Tar and grease on the outside of the trailer should be cleaned off using mineral spirits. To clean the tank, use a high pressure sprayer.

Short Term Storage

Properly maintaining the trailer between events will increase the life of the trailer and prevent unwanted odors. Before discussing the proper methods of storage, always remember to pump the waste and remove the fresh water from your restroom trailer before transporting. When the trailer returns from an event, clean the inside as you would a bathroom at home, with standard household cleaners, towels and a broom or mop depending on floor condition. Wipe down all surfaces making sure the interior is clean and dry.

Other steps for proper storage include making sure all doors are locked and sealed to prevent rain, snow, or bugs from entering the trailer. With the Satellite Suites trailer the roof vents can remain open in mild weather to allow fresh air to circulate (Maxx Air covers keep the rain out). Make sure all breakers are turned off and that all steps and handrails have been returned to their locked travel position.

Following these basic steps will ensure a long, low-maintenance life for your restroom trailer.

WARRANTY



3 -Year Limited Product Warranty

Satellite Industries, Inc. hereby warrants to the original purchaser that the Satellite Suites™ restroom trailer will be free of manufacturing defects in materials and workmanship for a period of three years from the date of shipment. If upon examination by Satellite Suites™, or our representative, any covered part or parts are determined to be defective Satellite will provide, free of charge, the repair or replacement of said items at Satellite's discretion. This warranty is subject to the following exclusions and limitations.

1. Customer Responsibility: The customer shall be responsible for normal maintenance and adjustments of the products. Notification must be made to Satellite Suites™ of the need for warranty repairs. Satellite will not be liable for transportation costs to and from repair facility, loss of revenue from down time or cost of rental equipment.
2. This warranty does not apply to components or accessories not manufactured by Satellite which carry a manufacturer's written warranty: air conditioners, heaters, faucets, toilets, water pumps, converter, vent fans, power converter
 - a. In order to expedite claims, Satellite Suites will handle credit from manufacturer. Contact Satellite Suites at 574-350-2150.
 - b. Warranted part(s) must be returned to Satellite Suites in order for part to be covered.
 - i. Satellite Suites™, Attention: Warranty, 1686 Commerce Drive, Bristol, IN 46507
3. This warranty applies only to products placed in normal use. It does not apply to any product that has been abused, neglected (i.e. lubrication, tire pressure, transported with full waste tank etc.), exposed to abrasive or corrosive chemicals, damaged in an accident or failures caused by lack of routine maintenance or winterization per Satellite Suites™ winterization procedure (<https://www.satelliterestroomtrailers.com/resources/winterizing>). Items that have been altered or repaired by anyone other than Satellite or a repair facility authorized by Satellite will also be excluded from warranty coverage.

CLAIMS EXCLUDED FROM THIS WARRANTY

Satellite Suites™ is not responsible for claims relating to any of the following: (1) any type of defacing, including scratches, dents, chips, tears, or defacing on any surface not caused by the Manufacturer; (2) Floor wear; (3) damage due to unauthorized repairs, abuse, misuse, neglect, or overloading (as determined by the GVWR); (4) metal corrosion from fertilizers, cement, caustic chemicals etc., (5) damage caused by improper hitch ball or tow vehicle hook up; (6) damage caused by loose or improperly torqued lug nuts; (7) paint, decals, or graphics; (8) tow vehicle wiring; (9) tire alignment; (10) damage to any tow vehicle; (11) damage caused by acts of God or terrorism; (12) damage caused by theft of vandalism (12) damage caused by towing with water or waste in tank(s) and/or towing over the rated GVWR.

DISCLAIMER OF FURTHER WARRANTY

THE MANUFACTURER MAKES NO EXPRESS OR IMPLIED WARRANTIES OTHER THAN AS SPECIFICALLY SET FORTH IN THIS WARRANTY. NO EMPLOYEE OR AUTHORIZED REPRESENTATIVE HAS THE AUTHORITY TO CHANGE OR MODIFY THIS WARRANTY. IMPLIED WARRANTIES, INCLUDING THOSE OF MERCHANTABILITY, FITNESS FOR AN INTED PURPOSE ARE EXCLUDED TO THE EXTENT OF THE LAW AND WHEN NOT EXCLUDED ARE LIMITED TO A PERIOD OF ONE YEAR FROM SHIPMENT. IN NO EVENT SHALL SATELLITE INDUSTRIES, INC., BE LIABLE FOR INDIRECT, SPECIAL, CONSEQUENTIAL DAMAGES OR LIMITATIONS ON HOW LONG AN IMPLIED WARRANTY LASTS, SO THE ABOVE LIMITATIONS AND EXCLUSIONS MAY OR MAY NOT APPLY TO YOU. FOR WARRANTY SERVICE CONTACT SATELLITE SUITES™ AT 574-350-2150.