

INSTRUCTIONS for UNIVERSAL II SOAP / SANITIZER DISPENSER INSTALLATION

INTRODUCTION: Portable restrooms and accessories must be assembled according to approved assembly procedures. Variations in assembly could adversely affect product life and warranty.

UNIVERSAL II DISPENSERS



#25528 Kit- Univ Soap/San Disp 800ml (**DISPENSER ONLY IS #24945 Dispenser- Universal II 800ml**)



#25529 Kit- Univ Soap/San Disp 1000ml (**DISPENSER ONLY IS #24946 Dispenser- Universal II 1000ml**)



#25531 Kit- Univ Soap/San Disp Disc (**DISPENSER ONLY IS #24948 Dispenser- Universal II Disc**)



#25530 Kit- Univ Soap/San Disp Foam (**DISPENSER ONLY IS #24947 Dispenser- Universal II Foam**)



TOOLS: •Cordless/Electric Drill •#10 (0.193") or 3/16" Drill Bit •Rivet Gun •Tape measure •Marker •Phillips driver bit or screwdriver

All kits contain both the dispenser and the 18431 hardware kit. Dispensers are available without hardware kit.

***NOTE:** 800ml & 1000ml Dispensers have embossed lever with 800 / 1000, also the module is interchangeable, it can be used for 800ml & 1000ml soap or sanitizer refills. Disc Dispenser has module that can only be used for Disc refills & has embossed DISC lever that can only be used with Disc refills. Foaming Dispenser has module that can only be used for Foaming refills & has embossed FOAM lever that can only be used with Foaming refills.



2530 Xenium Lane North, Minneapolis, MN 55441
Telephone: 763-553-1900 / Fax: 763-553-1905
800-328-3332/ www.satelliteindustries.com

INSTALLING UNIVERSAL DISPENSERS IN HANDWASH UNITS & RESTROOMS:

To open Universal dispenser cover, push up on button back behind lever at bottom of backplate & cover will pop open.

Locations on backplate used to mount Universal Dispensers in Restrooms & Handwash / Sanitizer products. Top center hole in Universal dispenser backplate. Bottom holes on the right and left side of dispenser backplate (whichever 2 bottom holes are easiest to transfer drill through, unless there are product specific information on which holes need to be used to install dispenser).

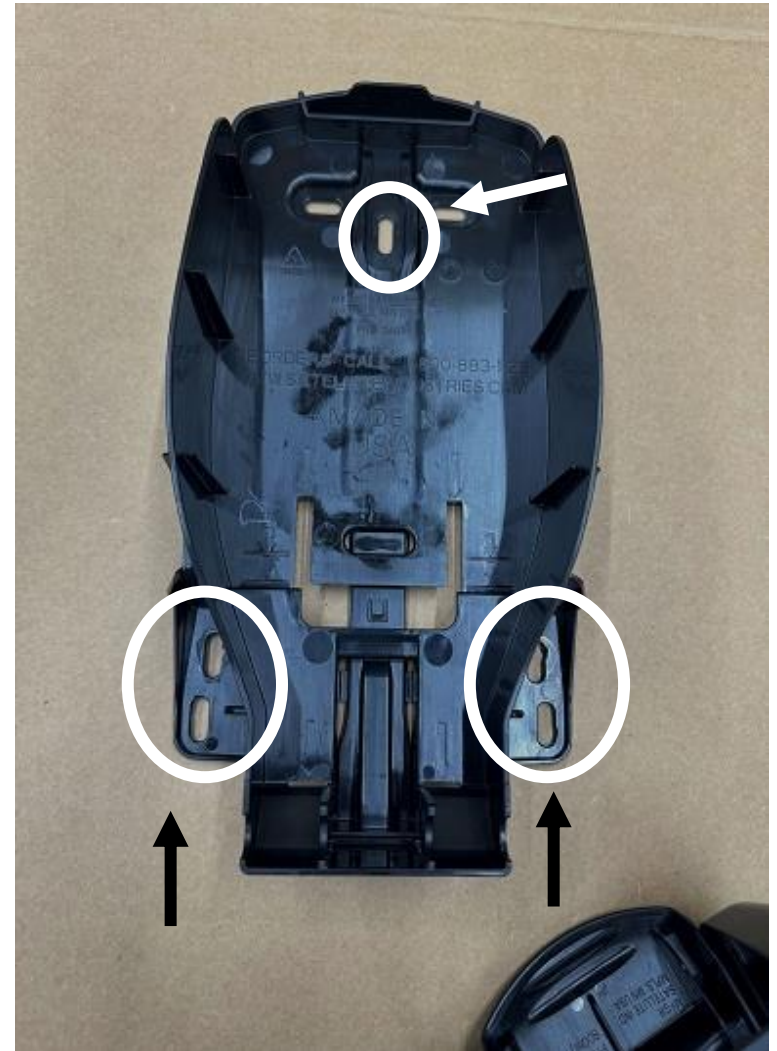
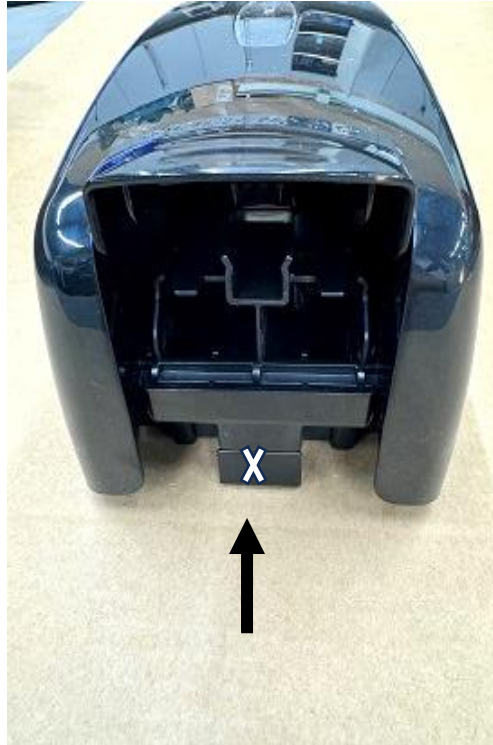

INSTALLED MODULES IN UNIVERSAL DISPENSERS



800 ml Module in dispenser



Foaming Module in dispenser

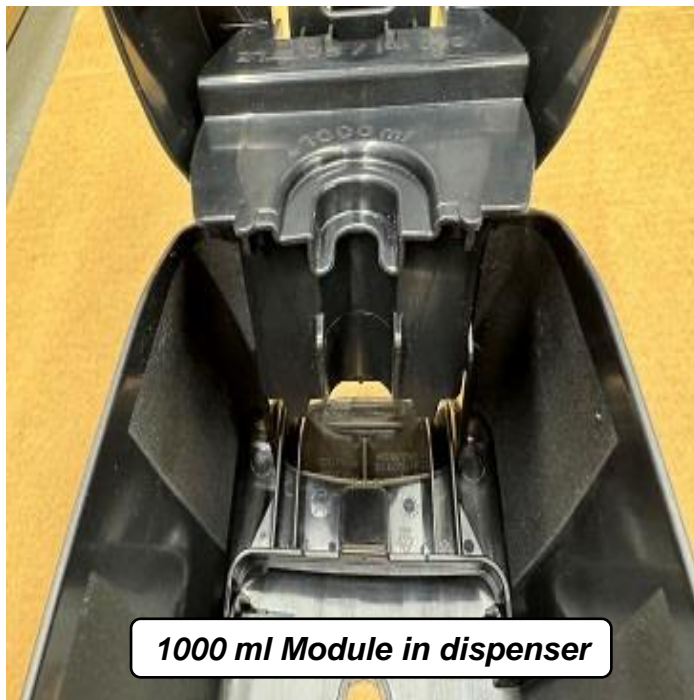

1000 ml Module in dispenser

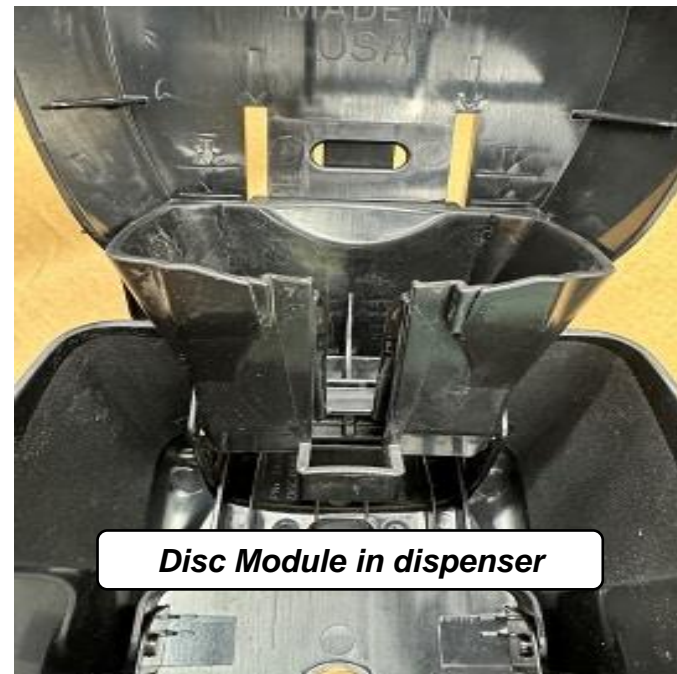

Disc Module in dispenser

Should you ever need to replace or change the module and lever, the following 3 pages describe how to remove and install them.

TO REMOVE MODULES IN UNIVERSAL DISPENSERS: *Open Universal dispenser cover, push up on bottom button & cover will pop open.* To remove module from backplate press down on tab located on backplate of dispenser near top of module (press between arrow icons on tab of backplate). With tab depressed, slide module up to remove from back plate of dispenser. **NOTE:** cover is held on dispenser by module & cover will fall from dispenser backplate when module is removed. So, support the cover while removing the module to prevent damage.

Remove module from backplate

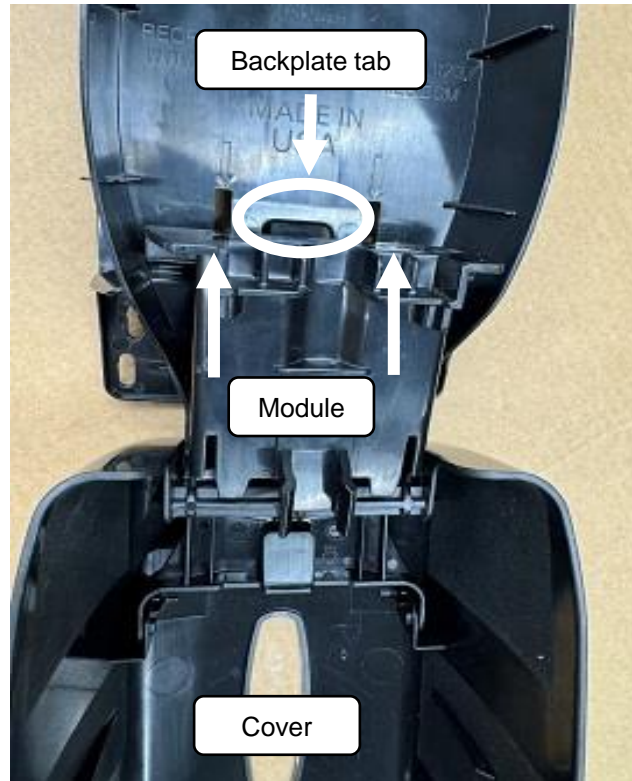
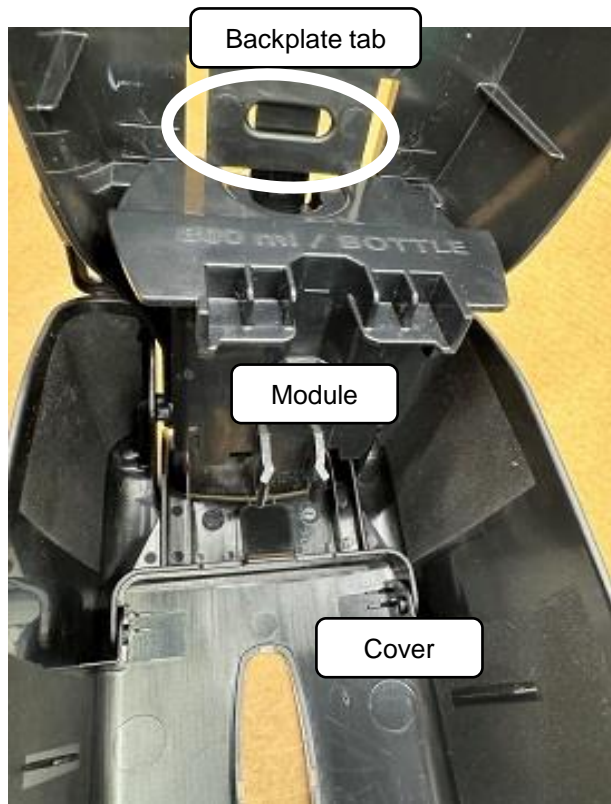

Universal Dispenser disassembled

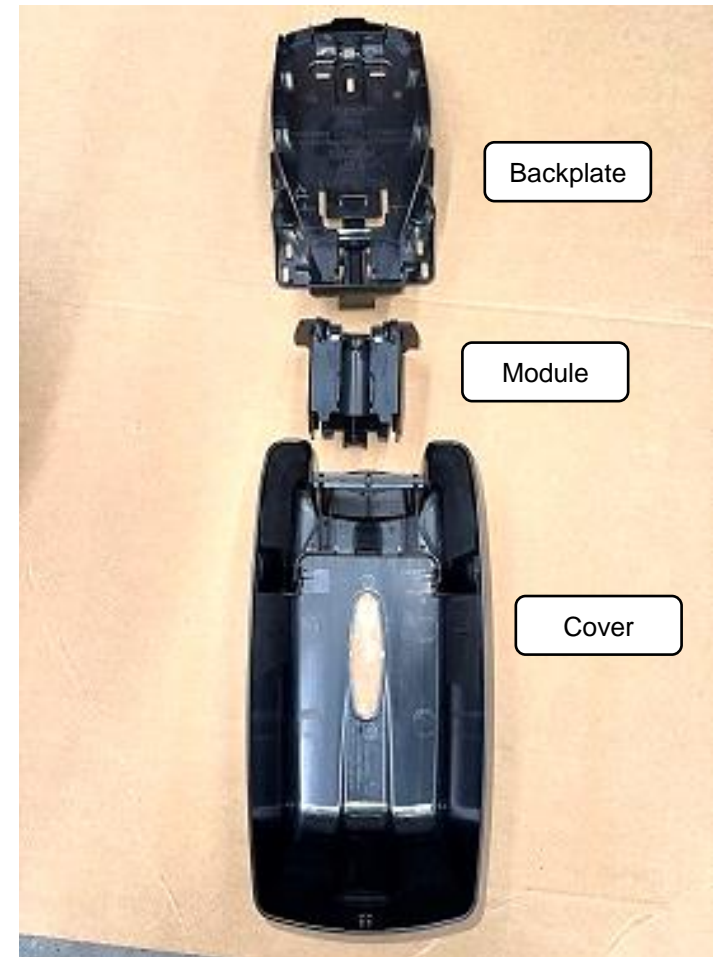

TO INSTALL MODULES IN UNIVERSAL DISPENSERS: Place cover hinge rod in bottom cradle of backplate (Cover hinge rod must be placed completely in Backplate cradle to get proper fit of module on backplate). Place back of module against backplate with the bottom cradle of module down just above Cover hinge rod. Slide module down on backplate pushing in at top of module where it is contacting tab on backplate. Push down on module until tab on back plate pops out & holds module / cover rod in position on backplate *Note: removing & installing module may take some effort due to snug fit of parts, that is normal as a tight fit is needed to get proper fit of the module on the backplate.* ***NOTE: 800 ML or 1000 ML dispenser use same module, it has to be rotated so 800 ML or 1000 ML icon on top of module is facing the front of dispenser, For example 800 ML icon at front of dispenser for 800ML refill (lever of dispenser is already embossed with both 800 ML / 1000 ML icon).**

Install modules in Dispensers

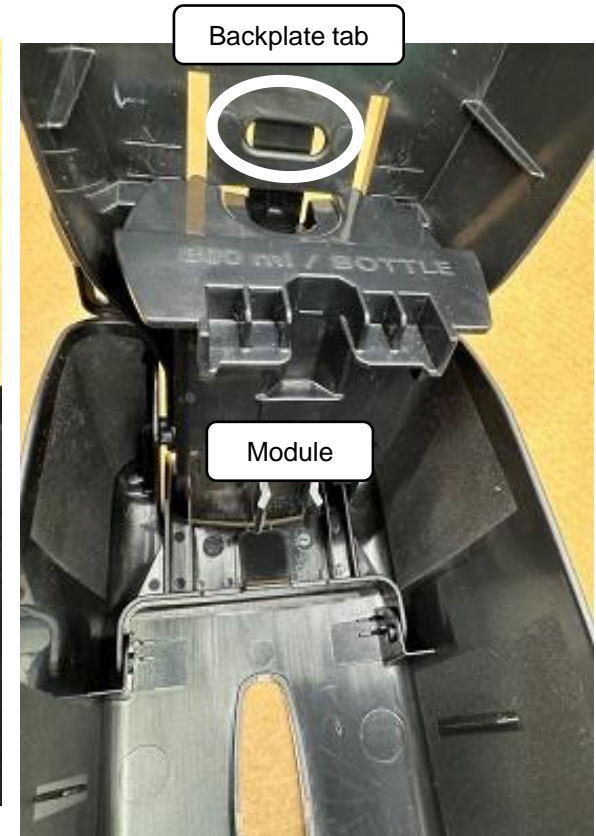
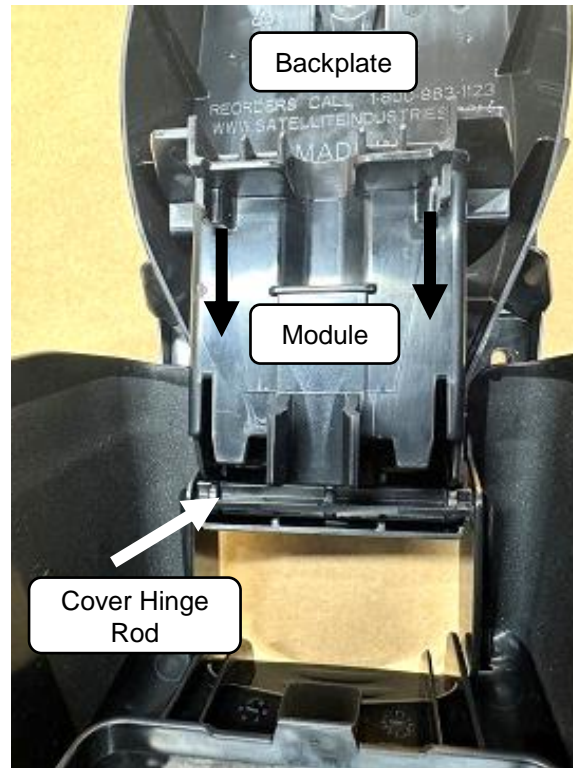

****See pages 7 and 8 for photos of all modules and refills installed in dispensers.***

REMOVING UNIVERSAL DISPENSERS LEVER: Open Universal dispenser cover, locate two arms of the lever that are connected to the cover. Push out on one arm so pin at end of arm is out of hole in tab on cover & pull up on arm, then move lever so other pin is out from opposite tab on dispenser cover. To install lever on cover, make sure the embossed lever with either **800 / 1000, DISC, or FOAMING** is facing outward when installed on cover. Insert pin at end of one arm into hole in tab on cover. Push out on other arm so pin at end of arm can be inserted in hole in the other tab on cover



Dispenser lever at bottom of cover



Lever arms with pins at ends

Lever embossed on outside with either **800 / 1000, DISC, or FOAM**



Lever arms attached to tabs on cover



Dispenser lever arm pushed out so pin is out of hole in tab on cover

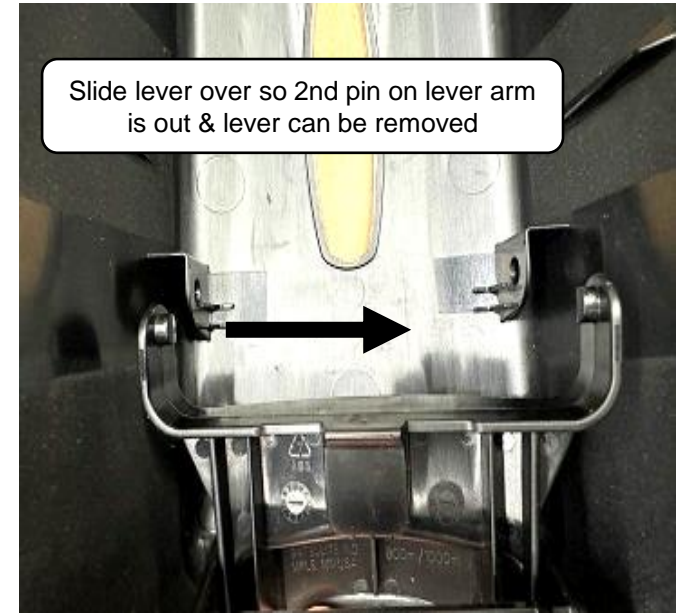

Slide lever over so 2nd pin on lever arm is out & lever can be removed

Installing refills in Dispensers:

800 ml refill: Insert 800 ml refill with nipple of refill in module channel as shown & push refill bag, bottle, or box towards the backplate of dispenser & close cover. Note: may need to tuck in edges of bag while closing the cover. The 800ml module and lever work with both the 800ml bag refill, 800ml boxed refill, and the 800ml refillable bottle.

800 ml bag refill installed in dispenser



800 ml refill nipple properly inserted in module

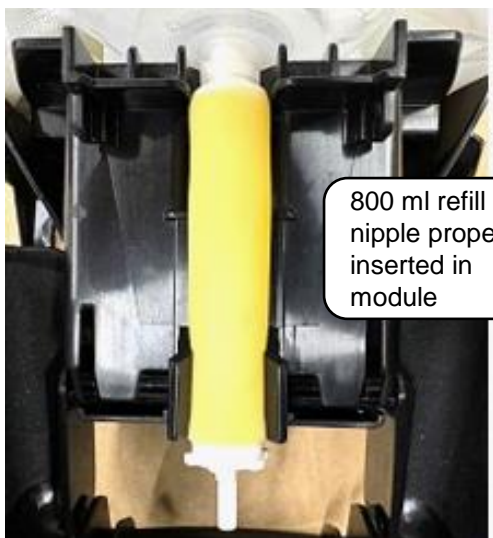

800 ml refillable bottle installed in dispenser



1000 ml refill: Insert 1000 ml refill with nipple of refill in module channel as shown & push refill bag towards the backplate of the dispenser & close cover. Note: may need to tuck in edges of bag while closing the cover.

1000 ml bag refill installed in dispenser



1000 ml refill nipple properly inserted in module



Installing refills in Dispensers:

Disc refill: Insert Disc refill with nozzle of refill inserted fully in pocket of module as shown (should snap into position in module) & push refill bag towards the backplate of dispenser & close cover. Note: may need to tuck in edges of bag while closing the cover. To remove Disc refill, pull out on disc nozzle while pulling up out of module.



Foaming refill: Insert Foaming refill with plate above nozzle positioned as shown. Insert plate fully in slots of module as shown (should snap into position in module) & push refill bag towards the backplate of dispenser & close cover. Note: may need to tuck in edges of bag while closing the cover. To remove refill push in tab on left side of plate above nozzle & slide plate out from module.



INSTALLING UNIVERSAL DISPENSERS IN HANDWASH UNITS & RESTROOMS: To open Universal dispenser cover, push up on bottom button back behind lever in middle of & cover will pop open allowing installation of rivets in back plate.

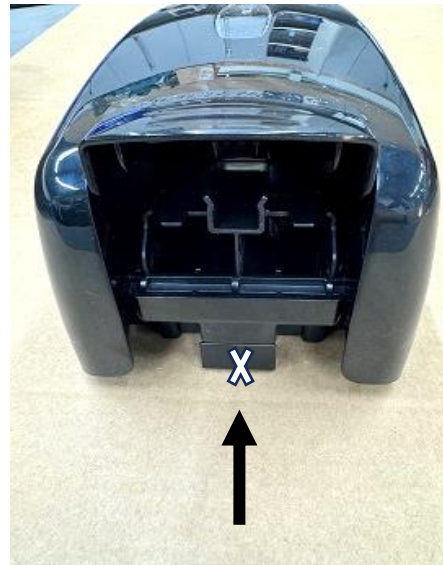

BREEZE AND WAVE

For all Universal II Dispensers Drill out top dimple shown below using #10 drill bit. With cover open fasten dispenser at top center hole in backplate with #17436 Rivet. Then transfer drill through 2 bottom holes on the right and left side of dispenser backplate and fasten with (2) #17436 rivets.

BREEZE

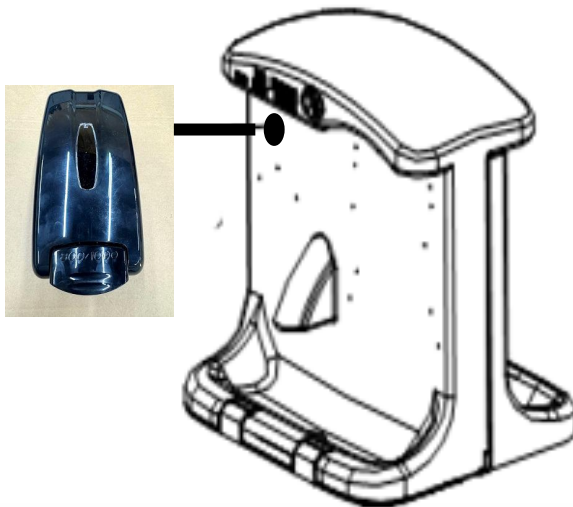

WAVE

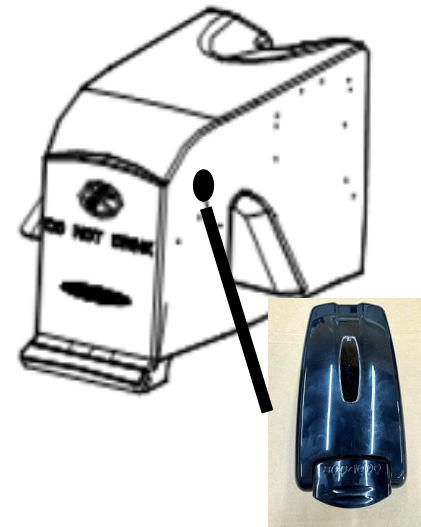

TUFWAY®

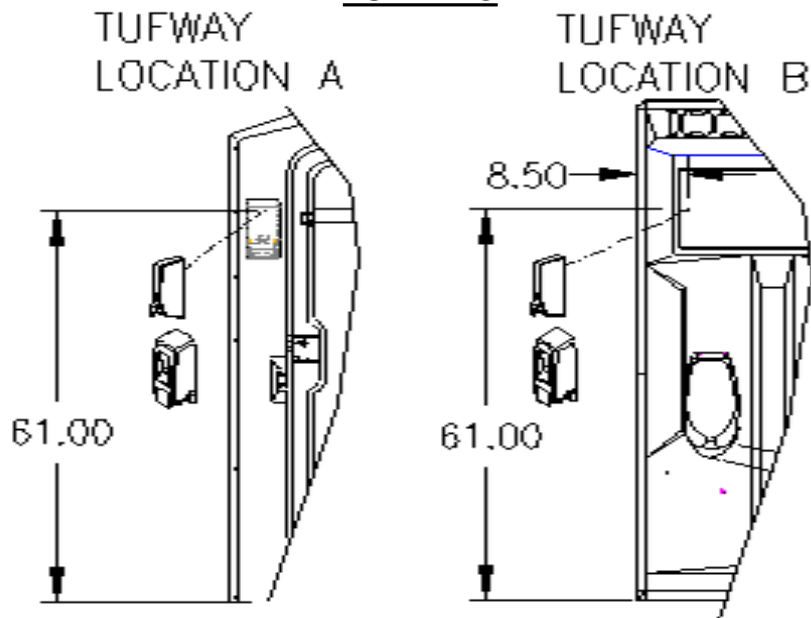

Location "A" For all Universal II Dispensers Place dispenser with cover open centered on inside of right facing (hasp side) with top center hole in dispenser backplate up 61" from base floor. Mark at top center hole of dispenser mount plate and drill using #10 drill bit (**Through inside wall Only**). Fasten dispenser with #17436 Rivet. Then transfer drill through 2 bottom holes on the right and left side of dispenser backplate and fasten with #17436 rivets.

Location "B" For all Universal II Dispensers Place dispenser with cover open on inside of left panel with top hole in dispenser backplate up 61" from base floor & over 8-1/2" from inside of front facing. Mark at top center hole of dispenser backplate and drill using #10 drill bit. Fasten with #11027 rivet (outside on panel) & #11315 washer (inside on rivet). Then transfer drill through 2 bottom holes on the right and left side of dispenser backplate and fasten with #11027 rivets (outside on panel) & #11315 washers (inside on rivets).

GLOBAL II™



Location "A" For all Universal II Dispensers Place dispenser with cover open centered on inside of right facing (hasp side) with top center hole in dispenser backplate up 58-1/2" from base floor. Mark at top center hole of dispenser backplate and drill using #10 drill bit (**Through inside wall Only**). Fasten dispenser with #17436 Rivet. Then transfer drill through 2 bottom holes on the right and left side of dispenser backplate and fasten with #17436 rivets.

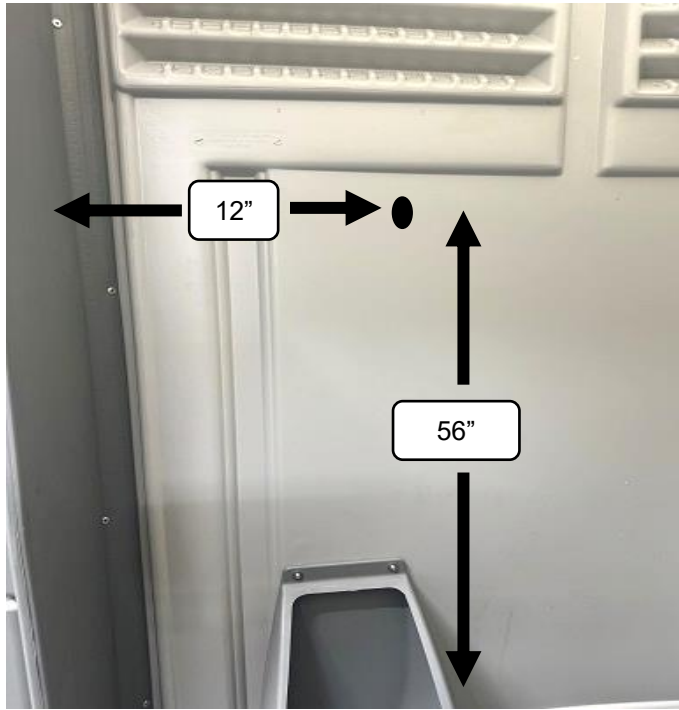

Location “B” For all Universal II Dispensers Place dispenser with cover open on inside of left panel with top hole in dispenser backplate up 56” from base floor & over 12” from inside of front facing. Mark at top center hole of dispenser backplate and drill using #10 drill bit. Fasten with #11027 rivet (outside on panel) & #11315 washer (on rivet). Then transfer drill through 2 bottom holes on the right and left side of dispenser backplate and fasten with Fasten with #11027 rivets (outside on panel) & #11315 washers (inside on rivets).

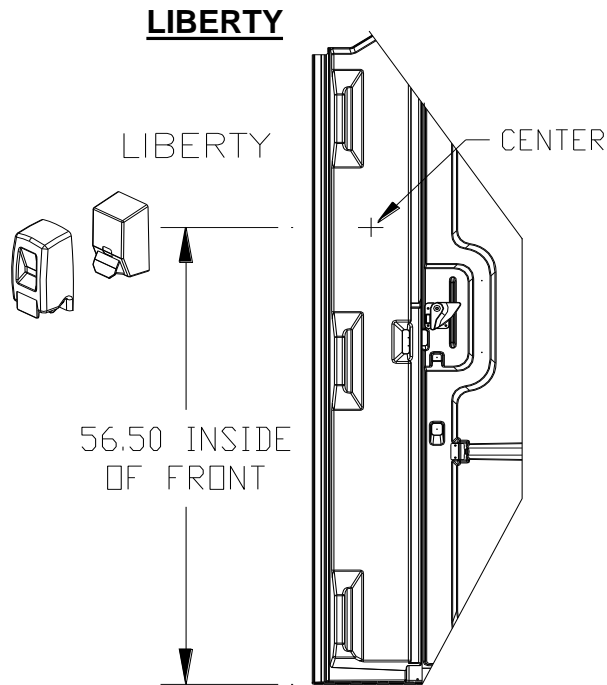

For all Universal II Dispensers Place dispenser with cover open centered on inside of right facing (hasp side) with top center hole in dispenser backplate up 56-1/2” from base floor. Mark at top center hole of dispenser mount plate and drill using #10 drill bit **(Through inside wall Only)**. Fasten dispenser with #17436 Rivet. Then transfer drill through 2 bottom holes on the right and left side of dispenser backplate and fasten with #17436 rivets.

AXXIS



LOCATION "A" For all Universal II Dispensers

Place dispenser with cover open on inside of right panel centered on panel feature shown. With top center hole in dispenser up 59" from floor of base. Left side of dispenser on right edge of the logo area of panel. Mark at top center hole of dispenser backplate and drill using #10 drill bit. Fasten with #11027 rivet (outside on panel) & #11315 washer (on rivet). Then transfer drill through 2 bottom holes on the right and left side of dispenser backplate and fasten with #11027 rivets (outside on panel) & #11315 washers (on rivets).



LOCATION "B" For all Universal II Dispensers

Place dispenser with cover open on inside of left panel centered on panel feature shown. With top center hole in dispenser up 59" from floor of base. Right side of dispenser on left edge of the logo area of panel. Mark at top center hole of dispenser backplate and drill using #10 drill bit. Fasten with #11027 rivet (outside on panel) & #11315 washer (on rivet). Then transfer drill through 2 bottom holes on the right and left side of dispenser backplate and fasten with #11027 rivets (outside on panel) & #11315 washers (on rivets).

AXXIS (BM) Blow Mold front



Location “A” For all Universal II Dispensers On inside of front locate dimple 56-1/4” up from floor on right facing (hasp side) and drill at dimple using #10 drill bit (**Through inside wall Only**). Fasten dispenser top center hole in dispenser backplate with #17436 Rivet. Then transfer drill through 2 bottom holes on the right and left side of dispenser backplate and fasten with #17436 rivets.

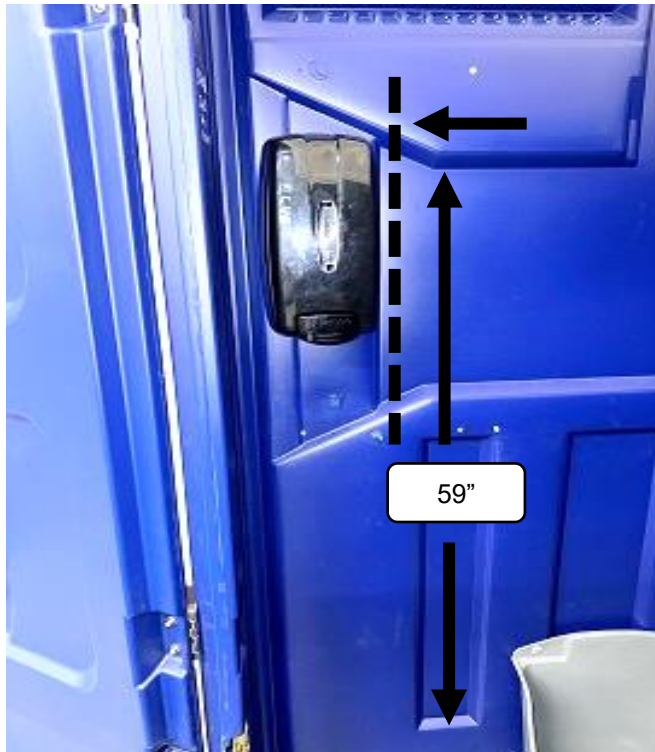

LOCATION “B” For all Universal II Dispensers Place dispenser with cover open on inside of left panel centered on panel feature shown. With top center hole in dispenser up 59” from floor of base. Right side of dispenser on left edge of the logo area of panel. Mark at top center hole of dispenser backplate and drill using #10 drill bit. Fasten with #11027 rivet (outside on panel) & #11315 washer (on rivet). Then transfer drill through 2 bottom holes on the right and left side of dispenser backplate and fasten with #11027 rivets (outside on panel) & #11315 washers (on rivets).

MAXIM 3000 II

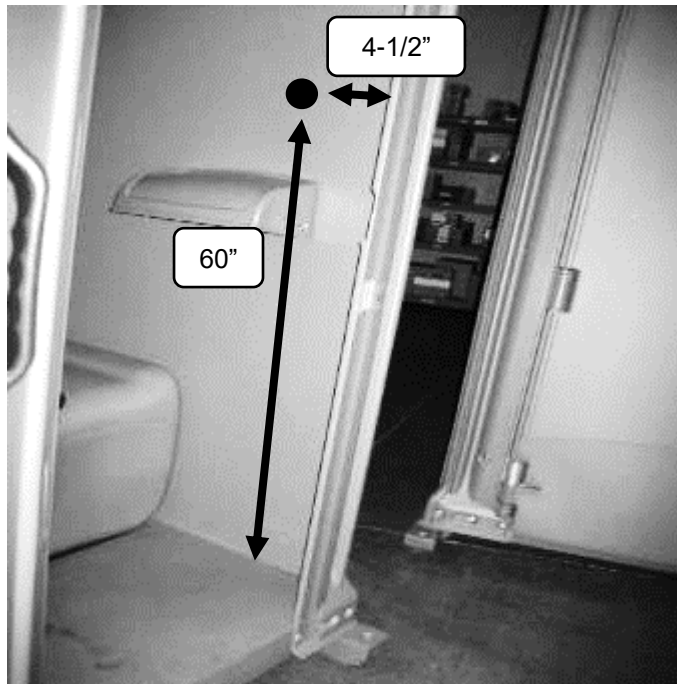

LOCATION "A" For all Universal II Dispensers Mark right panel 60" up from floor & over 4-1/2" from finger groove feature in right panel (near where right panel is connected to front). Drill at mark on panel using #10 drill bit (**Through inside wall only**). With cover open fasten dispenser at top center hole in backplate with #17436 Rivet. Then transfer drill through 2 bottom holes on the right and left side of dispenser backplate and fasten with #17436 rivets. **NOTE: if there are issues installing #17436 rivets there is an option of using #11024 rivets & #11315 washers. Would need to drill through both inside & outside wall of panels. Then fasten dispenser with #11024 rivets (outside on panel) & #11315 washers (on rivets).**

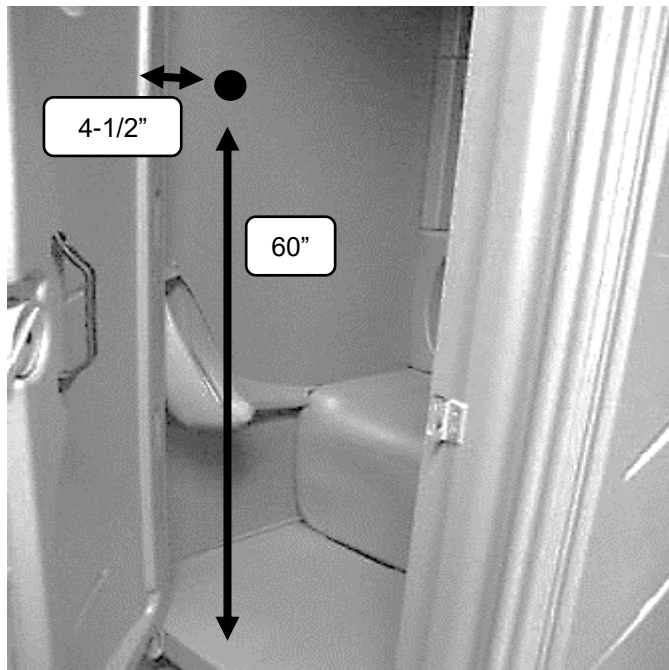

LOCATION "B" For all Universal II Dispensers Mark left panel 60" up from floor & over 4-1/2" from finger groove feature in left panel (near where left panel is connected to front). Drill at mark on panel using #10 drill bit (**Through inside wall only**). With cover open fasten dispenser at top center hole in backplate with #17436 Rivet. Then transfer drill through 2 bottom holes on the right and left side of dispenser backplate and fasten with #17436 rivets. **NOTE: if there are issues installing #17436 rivets there is an option of using #11024 rivets & #11315 washers. Would need to drill through both inside & outside wall of panels. Then fasten dispenser with #11024 rivets (outside on panel) & #11315 washers (on rivets).**

MAXIM 2000®

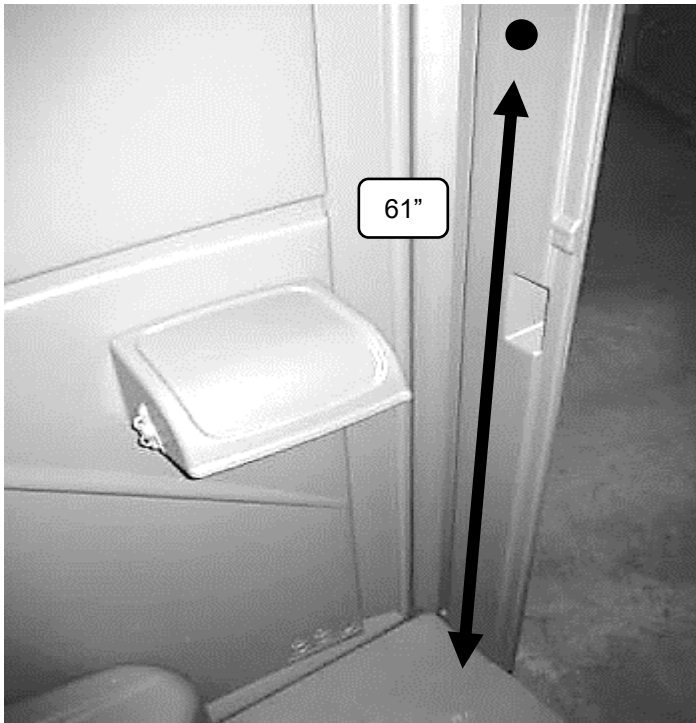

LOCATION “A” For all Universal II Dispensers Place dispenser with cover open centered on inside of right facing (hasp side) with top center hole in dispenser backplate up 61” from base floor. Mark at top center hole of dispenser backplate and drill using #10 drill bit **(Through inside wall Only)**. Fasten dispenser with #17436 Rivet. Then transfer drill through 2 bottom holes on the right and left side of dispenser backplate and fasten with #17436 rivets.

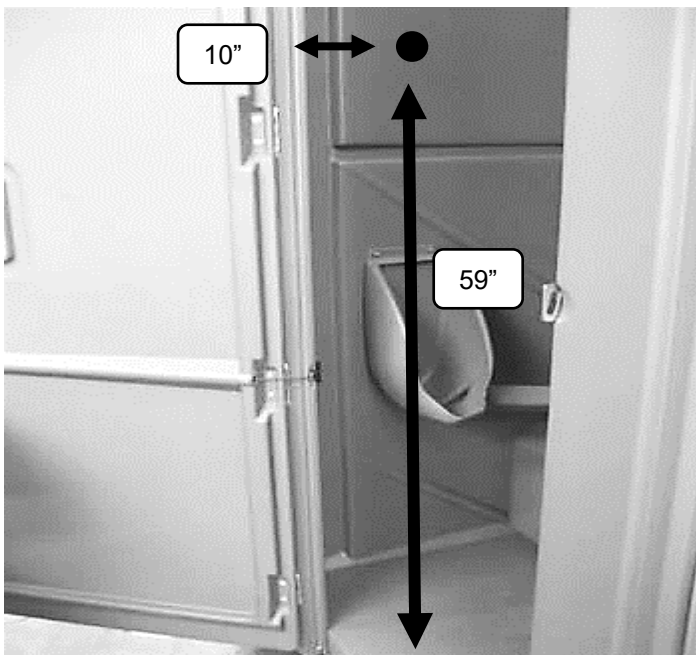

LOCATION “B” For all Universal II Dispensers Place dispenser with cover open on inside of left panel with top hole in dispenser backplate up 59” from base floor & over 10” from inside of front facing. Mark at top center hole of dispenser backplate and drill using #10 drill bit. Fasten with #11027 rivet (outside on panel) & #11315 washer (on rivet). Then transfer drill through 2 bottom holes on the right and left side of dispenser backplate and fasten with #11027 rivets (outside on panel) & #11315 washers (on rivets).

Aspen II

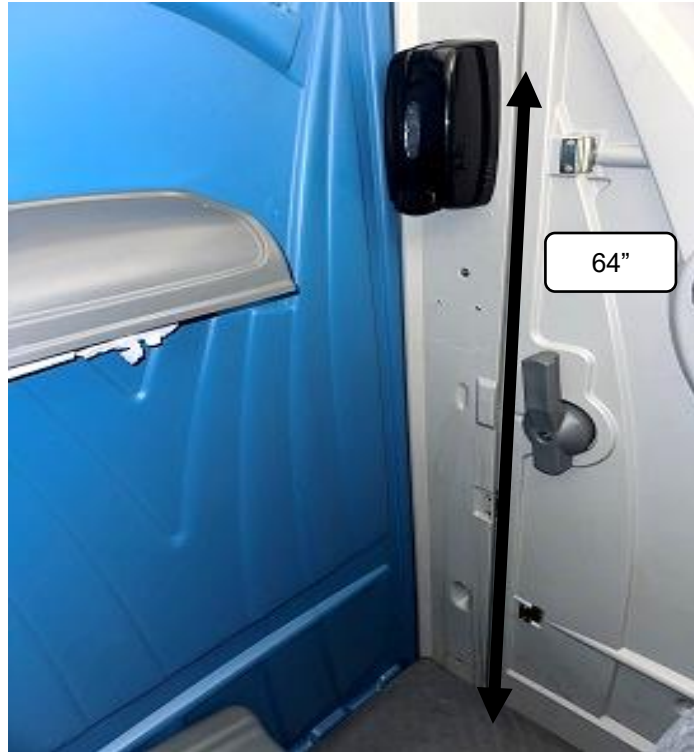

LOCATION "A" For all Universal II Dispensers Place dispenser with cover open on right facing with top center hole in dispenser backplate up 64" from base floor & dispenser right edge on right edge of front facing (hasp facing). Mark at top center hole of dispenser backplate and drill using #10 drill bit. Fasten with #17436 rivet. Then transfer drill through 2 bottom holes on the right side and left side of dispenser backplate and fasten with #11027 rivets (inside on backplate). **NOTE: if there are issues installing #17436 rivets in bottom holes there is an option of using #11027 rivets.**



LOCATION "B" For all Universal II Dispensers Place dispenser with cover open on left panel with top center hole in dispenser backplate up 60" from base floor & left edge of dispenser over 8-1/2" to feature on panel as shown. Mark at top center hole of dispenser backplate and drill using #10 drill bit. Fasten with #11027 rivet (outside on panel) & #11315 washer (on rivet). Then transfer drill through 2 bottom holes on the right and left side of dispenser backplate and fasten with #11027 rivets (outside on panel) & #11315 washers (on rivets).

Aspen / Glacier II (Old version units only)

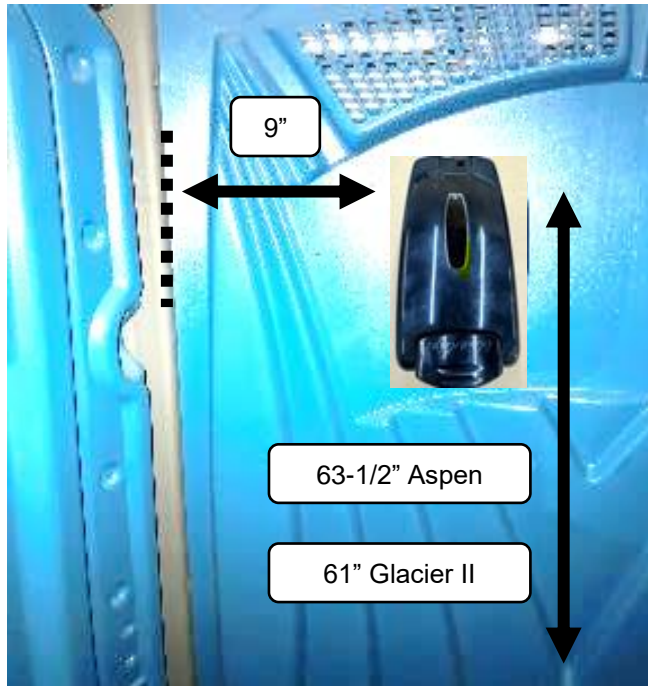

LOCATION "A" For all Universal II Dispensers (Only location for these restrooms) Place dispenser with cover open on left panel with top center hole in dispenser backplate up 63-1/2" (Aspen) 61" (Glacier II) from base floor & 9" from left edge of dispenser to right edge of front corner extrusion. Mark at top center hole of dispenser backplate and drill using #10 drill bit. Fasten with #11027 rivet (outside on panel) & #11315 washer (on rivet). Then transfer drill through 2 bottom holes on the right and left side of dispenser backplate and fasten with Fasten with #11027 rivets (outside on panel) & #11315 washers (on rivets).

HIGH RISE™

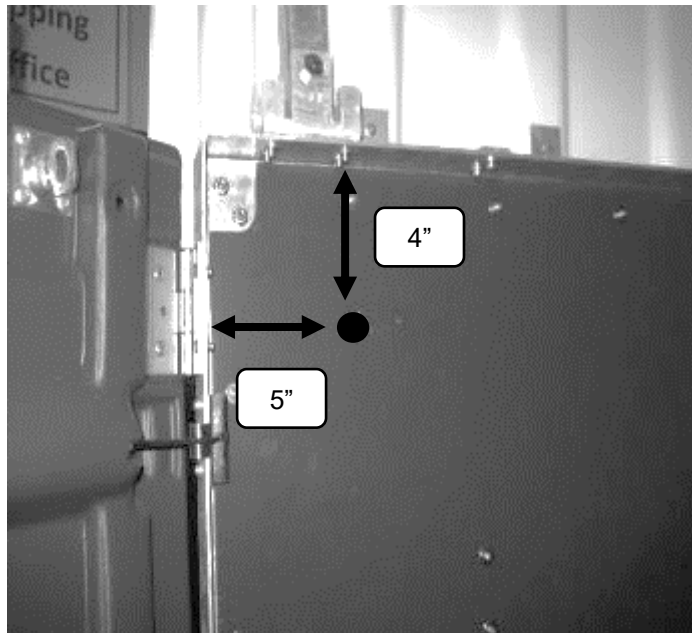

For all Universal II Dispensers Locate on Left panel in top front corner. Measure down from inside of top angle 4" & over from inside of hinge angle 5" & mark panel. Drill at mark with #10 drill bit. Place dispenser with cover open on inside of left panel. Fasten dispenser at top center hole in backplate with #11027 rivet (outside on panel) & #11315 washer (on rivet). Then transfer drill through 2 bottom holes on the right and left side of dispenser backplate and fasten with #11027 rivets (outside on panel) & #11315 washers (on rivets).

FREEDOM 3 & 4

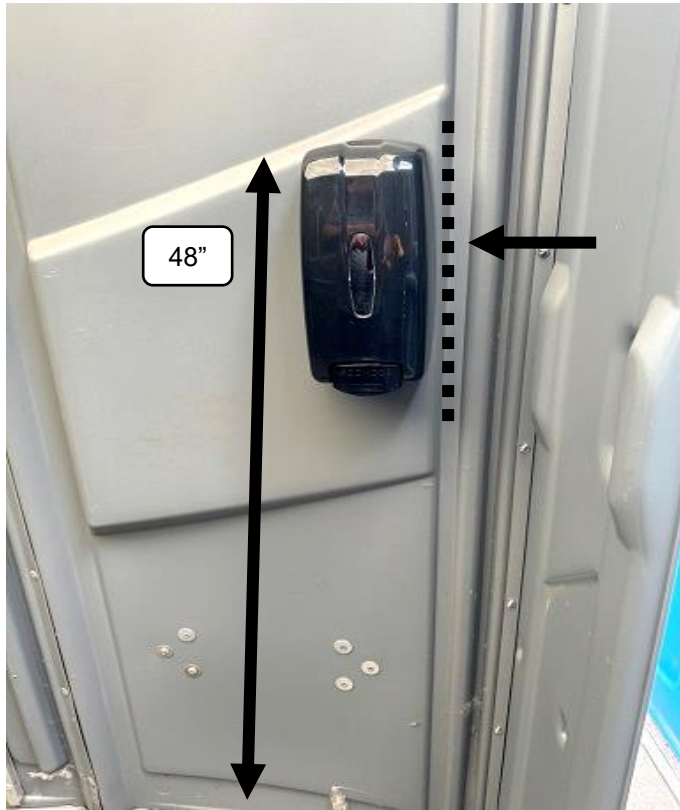

For all Universal II Dispensers (Only location for these restrooms) Place dispenser on inside of right half panel 48" from floor to top of dispenser. Right side of dispenser in line with feature on right half panel. With cover open mark at top center hole of dispenser backplate on panel and drill at mark using #10 drill bit. Fasten with #11027 rivet (outside on panel) & #11315 washer (on rivet). Then transfer drill through 2 bottom holes on the right and left side of dispenser backplate and fasten with #11027 rivets (outside on panel) & #11315 washers (on rivets).



TAURUS

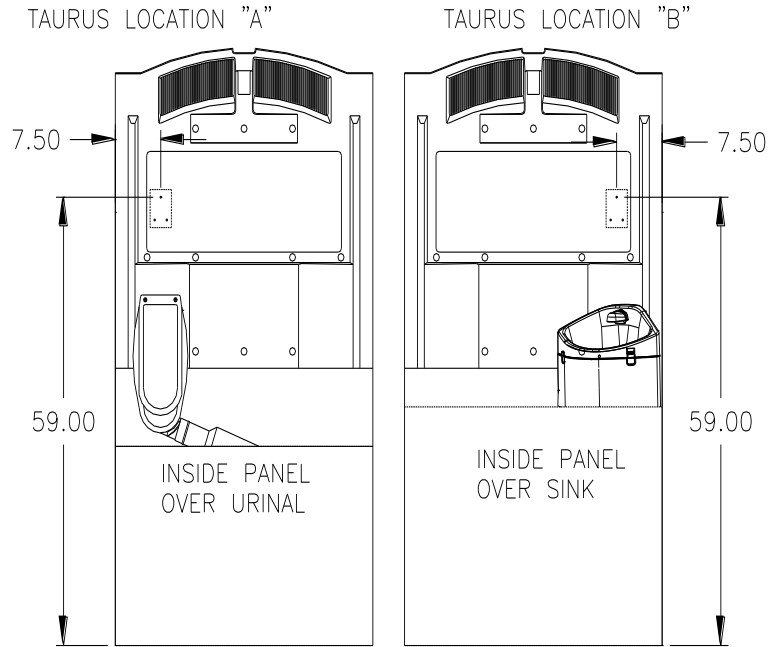

HIGH TECH

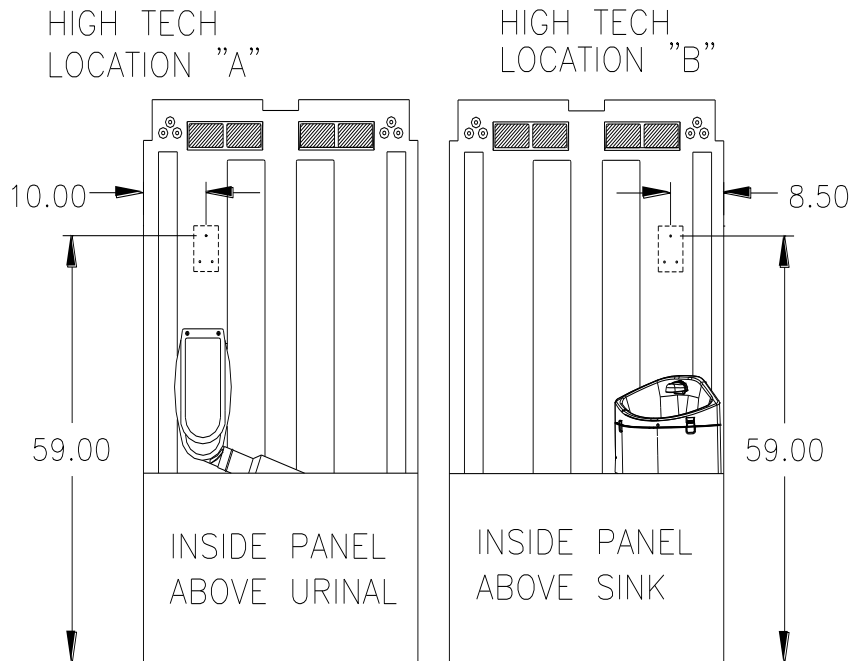

LOCATION "A" For all Universal II Dispensers Place dispenser with cover open on left panel with top hole in dispenser backplate up 59" from base floor & over 7-1/2" from inside of front facing. Mark at top center hole of dispenser backplate and drill using #10 drill bit. Fasten with #11027 rivet (outside on panel) & #11315 washer (on rivet). Then transfer drill through 2 bottom holes on the right and left side of dispenser backplate and fasten with Fasten with #11027 rivets (outside on panel) & #11315 washers (on rivets).

LOCATION "B" For all Universal II Dispensers Place dispenser with cover open on right panel with top hole in dispenser backplate up 59" from base floor & over 7-1/2" from inside of front facing. Mark at top center hole of dispenser backplate and drill using #10 drill bit. Fasten with #11027 rivet (outside on panel) & #11315 washer (on rivet). Then transfer drill through 2 bottom holes on the right and left side of dispenser backplate and fasten with Fasten with #11027 rivets (outside on panel) & #11315 washers (on rivets).

LOCATION "A" For all Universal II Dispensers Place dispenser with cover open on left panel with top hole in dispenser backplate up 59" from base floor & over 10" from inside of front facing. Mark at top center hole of dispenser backplate and drill using #10 drill bit **(Through inside wall Only)**. Fasten with #17436. Then transfer drill through 2 bottom holes on the right and left side of dispenser backplate and fasten with Fasten with #17436 rivets.

LOCATION "A" For all Universal II Dispensers Place dispenser with cover open on right panel with top hole in dispenser backplate up 59" from base floor & over 8-1/2" from inside of front facing. Mark at top center hole of dispenser backplate and drill using #10 drill bit **(Through inside wall Only)**. Fasten with #17436. Then transfer drill through 2 bottom holes on the right and left side of dispenser backplate and fasten with Fasten with #17436 rivets.

TAG 4 HANDWASH STATION

For all Universal II Dispensers Drill at top dimple using #10 drill bit. With cover open fasten dispenser at top center hole in backplate with #17436 Rivet. Then transfer drill through 2 bottom holes on the right and left side of dispenser backplate and fasten with #17436 rivets.



HANDISTAND

For all Universal II Dispensers Drill at top dimple using #10 drill bit. With cover open fasten dispenser at top center hole in backplate with #17436 Rivet. Then transfer drill through 2 bottom holes on the right and left side of dispenser backplate and fasten with #17436 rivets.



BREEZE II

For all Universal II Dispensers Drill at top dimple using #10 drill bit. With cover open fasten dispenser at top center hole in backplate with #17436 Rivet. Then transfer drill through 2 bottom holes on the right and left side of dispenser backplate and fasten with #17436 rivets.

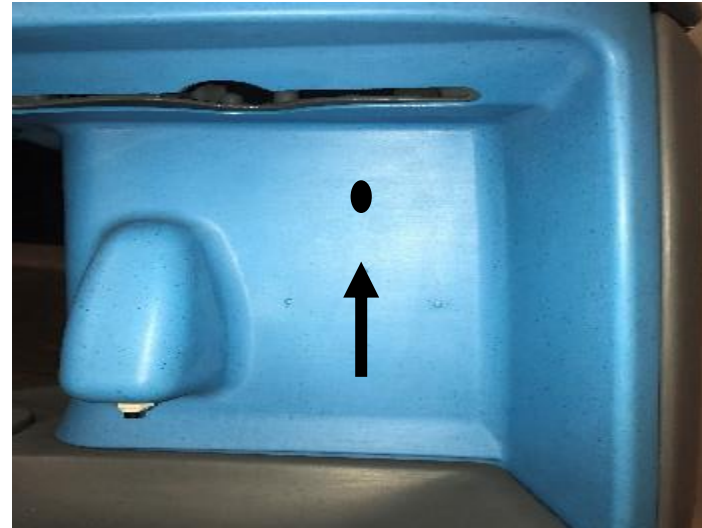

HANDISTAND II

For all Universal II Dispensers Drill at top dimple using #10 drill bit. With cover open fasten dispenser at top center hole in backplate with #17436 Rivet. Then transfer drill through 2 bottom holes on the right and left side of dispenser backplate and fasten with #17436 rivets.



AGWASH

There are 4 inserts in dispenser mount area shown. Screws #21466 are used in inserts.
DO NOT DRILL INTO AGWASH, ONLY USE SCREWS INTO INSERTS.



For all Universal II Dispensers Locate top hole & bottom left & right holes on sides of dispenser backplate that are line with inserts shown on Agwash. Use #2 Phillips driver bit to install screw PN 21466 at top center hole of dispenser backplate into insert. Install screws 21466 in 2 bottom holes in dispenser backplate that are inline with inserts.



MAXIM 3000®

MAXIM 3000
LOCATION A

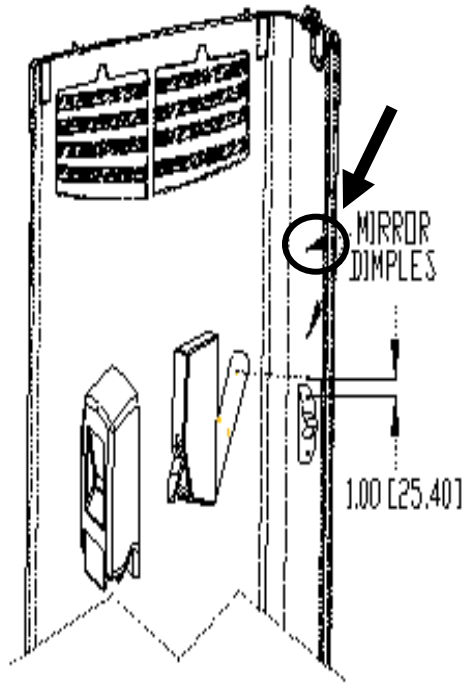

MAXIM 3000
LOCATION B

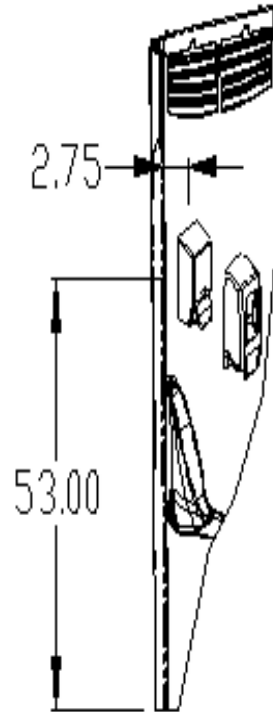

Location "A" For all Universal II Dispensers Locate upper dimple on right panel hasp side. Drill hole 1" above the dimple using a #10 drill bit (**Through inside wall Only**). Fasten at top center hole on dispenser backplate using #17436 Rivet. Use the backplate of dispenser as a template drill out bottom right slot hole at the top of the slot hole and fasten with #17436 rivet. **NOTE: no rivet in bottom left hole of dispenser.**

Location "B" For all Universal II Dispensers Mounting Above Urinal: Place dispenser with cover open on left panel with top hole in dispenser backplate up 53" from base floor & over 2-3/4" from edge of door opening. Mark at top center hole of dispenser backplate and drill using #10 drill bit (**Through inside wall Only**). Fasten at top center hole on dispenser backplate using #17436 Rivet. Then transfer drill through 2 bottom holes on the right and left side of dispenser backplate and fasten with #17436 rivets.



2530 Xenium Lane North, Minneapolis, MN 55441
Telephone: 763-553-1900 / Fax: 763-553-1905
800-328-3332/ www.satelliteindustries.com