

# SANITRAX URINAL MODULE

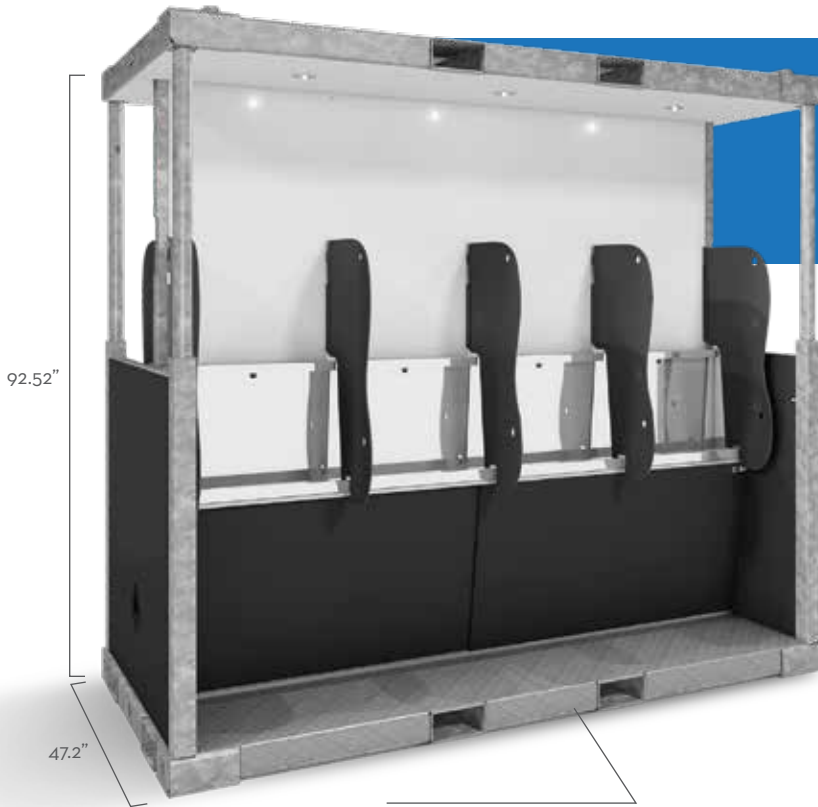

GALVANIZED STEEL FRAME

PRIVACY SHEETS

MODULAR DESIGN

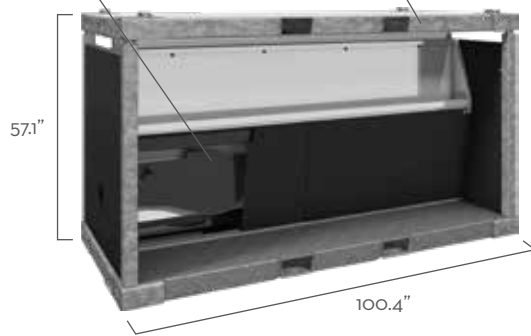

Satellite's Sanitrax Urinal is a standout solution, operational on both sides and equipped with advanced water-saving smart-flushing technology. This system discreetly collects urine in a hidden reservoir and ensures cleanliness by regularly flushing fresh water through the troughs.

The urinals feature built-in LED lighting, a luxurious finish, and an eye-catching design. For added privacy, optional sheets are available to enhance user confidentiality. These combined features make Satellite's Sanitrax Urinal the most comprehensive and impressive option on the market.

## TECHNICAL SPECIFICATIONS

**WEIGHT:** 1,750 lbs

**POWER:** 12V, 6W

**WATER USAGE:** Automatic

**WATER SUPPLY CONNECTION:** 3/4" M Camlock

**WASTE WATER DRAINAGE CONNECTION:** 2.5" M Camlock

**WASTE WATER SYSTEM:** Vacuum

**VACUUM PRESSURE IN BAR:** -0.3 to -0.6

**VACUUM PRESSURE IN PSI:** -4.3 to -8.7

**WATER PRESSURE IN BAR:** 3 to 5

**WATER PRESSURE IN PSI:** 40 to 90

**TRANSPORT:** 22 modules (176 individual urinals) on a 53' step deck trailer (depending on local regulations)

 **TWO SIDES MODULE**  **EASY TO CLEAN**  **EASY TO TRANSPORT**