



TRUCK DIVISION

TRAILERS, SLIDE-IN'S, RESTROOM, SEPTIC



TABLE OF CONTENTS

- 3 PIONEER TRAILERS:** PIONEER 1 LITE, PIONEER 1, PIONEER 2+
- 5 PIONEER UNIT HAULERS:** PIONEER 14 & 20 Unit Haulers
- 7 SLIDE-INS:** ALUMINUM, MILD STEEL, STAINLESS STEEL
- 9 P&D 700**
- 10 P&D 900**
- 11 P&D 1150**
- 12 MD 950**
- 13 MD 995** FLAT VAC
- 14 MD 1250**
- 15 MD 1600**
- 16 SS 1600**
- 17 MAL 1300**
- 18 MAL 2150**
- 19 CABOVER TRUCKS**
- 21 SINGLE-AXLE LARGE VACUUM**
- 22 TANDEM-AXLE LARGE VACUUM**
- 23 ACCESSORIES**



Ford, Chevrolet, Ram, Peterbilt, Hino, International,
Western Star, Freightliner, Kenworth, Mack, Isuzu

**Operators are responsible to not exceed the GVWR or GCWR on any of our trucks.*

HEAVY-DUTY ALUMINUM

PIONEER TRAILERS



PIONEER 1 LITE, PIONEER 1 & PIONEER 2+

Introducing the Pioneer Trailer line from Satellite Vacuum Trucks. We now offer two heavy-duty aluminum trailers and one lightweight aluminum trailer, perfect for hauling restrooms and sinks. Built to withstand the most rugged terrain, the Pioneer Trailer's compact design enhances both maneuverability and functionality.

- **TRAILER FINISH:** Pioneers 1 and 2+ have a 3" x 1/4" aluminum square tube frame covered with aluminum diamond plate that creates a strong non-slip surface for customers and operators alike.

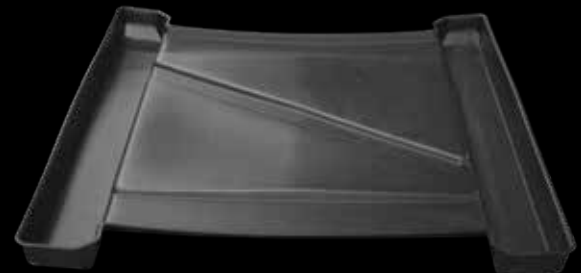

**Pioneer Trailer Containment Tray
(Optional)**



PIONEER 1 LITE

If you need a lightweight trailer with a compact footprint, look no further. Satellite Vacuum Trucks Pioneer 1 Lite Trailer is a smaller, lighter version of its predecessor, the Pioneer 1. Built with a lightweight aluminum frame this trailer is easy to maneuver by vehicle or by hand when fully loaded. The flip-down step adds extra stability when locked in the operational position, preventing tipping during use.

SPECS

Height: 50.25"

Width: 69.875"

Length/Steps: 116.437" / 121.125"

#of Units: 1

#of Sinks: 0

GVWR: 1,500 lbs

Weight: 245 lbs

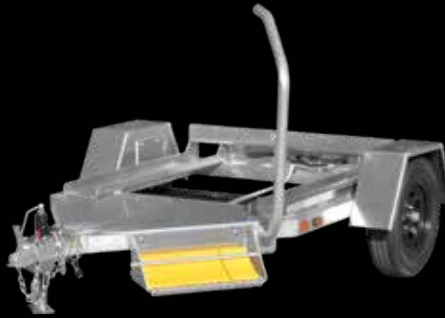

PIONEER 1

Satellite Vacuum Trucks Pioneer 1 Trailer is ideal for first responders and construction sites where mobility is crucial. With a heavy-duty aluminum frame and compact footprint, it navigates tight spaces and withstands rugged terrain. Designed for quick deployment, the Pioneer 1 Trailer features a wheel chock holder that doubles as a step, enhancing its functionality and versatility.

SPECS

Height: 51.58"

Width: 71.37"

Length: 98.3"

#of Units: 1

#of Sinks: 0

GVWR: 1,500 lbs

Weight: 332 lbs

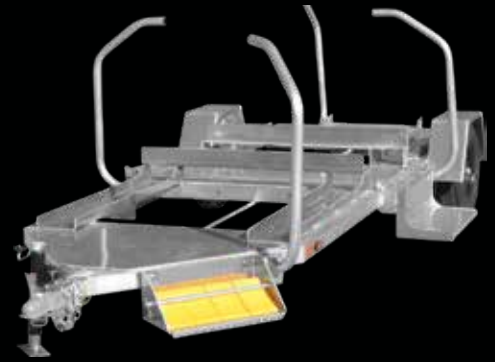

PIONEER 2+

The Pioneer 2+ Trailer adds exceptional value to every job site and emergency response team. With two restroom spots and one sink, this trailer is ready for any situation. Individual restroom access and dual side sink access ensure users won't cross paths. Built with a heavy-duty aluminum frame and a compact footprint, this trailer navigates tight areas and withstands rugged terrain.

SPECS

Height: 51.58"

Width / Steps: 71.37" / 83.47"

Length / Steps: 191.29" / 203.15"

#of Units: 2

#of Sinks: 1

GVWR: 1,600 lbs

Weight: 783 lbs

LIGHT WEIGHT. HEAVY DUTY

PIONEER UNIT HAULERS



PIONEER 14 & 20 UNIT HAULERS

Satellite's Pioneer 14 and Pioneer 20 Unit Haulers are built to make hauling easier, lighter, and more efficient. Featuring a durable all-aluminum construction, these trailers deliver strong, professional-grade performance while improving handling and efficiency on the road. Innovative front, side, and rear loading options provide unmatched flexibility in the field, making the Pioneer series the go-to choice for portable sanitation professionals who demand reliability, versatility, and smarter hauling.

- FRONT ALUMINUM STORAGE BOX
- LED LIGHTING





PIONEER 14 UNIT HAULER

Satellite's Pioneer 14 is designed to enhance the unit hauling experience through a lighter weight trailer than current steel unit haulers on the market. With its all-aluminum design, innovative front, side and rear loading features and robust performance, the Pioneer 14 has become the go-to unit hauler for many portable sanitation professionals.

SPECS

Height: 44" Tongue

Width: 102"

Length: 28' Deck

#of Units: 14

GVWR: 6,995 lbs

Material: Aluminum

Carrying Capacity: 2 5/16" ball receiver w/ 7 pin electrical

SPECS

Height: 44" Tongue

Width: 102"

Length: 40' Deck

#of Units: 20

GVWR: 6,995 lbs

Material: Aluminum

Carrying Capacity: 2 5/16" ball receiver w/ 7 pin electrical

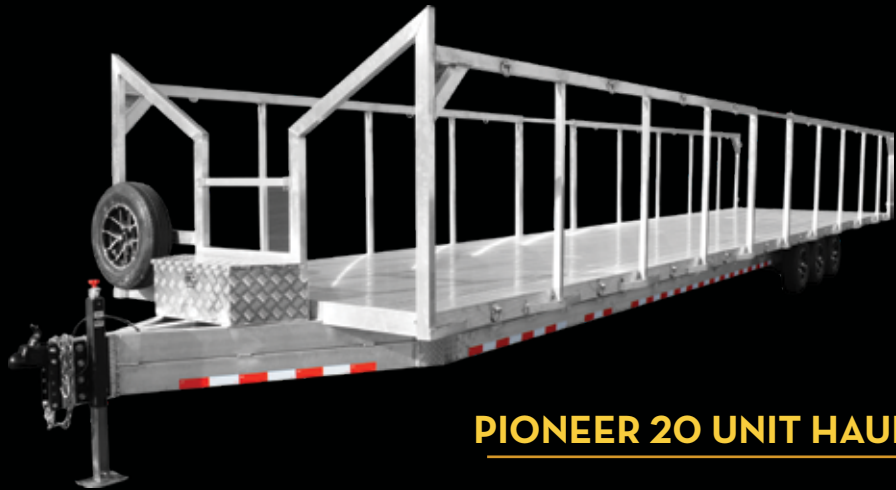

PIONEER 20 UNIT HAULER

Satellite's Pioneer 20 is designed to enhance high-capacity unit hauling with a lightweight, all-aluminum trailer built for efficiency and performance. Featuring innovative front, side, and rear loading capabilities and rugged, professional-grade construction, the Pioneer 20 has become the go-to unit hauler for portable sanitation professionals who need to move more without sacrificing reliability.

SMALL TANKS DOING BIG JOBS

SLIDE-IN TANKS

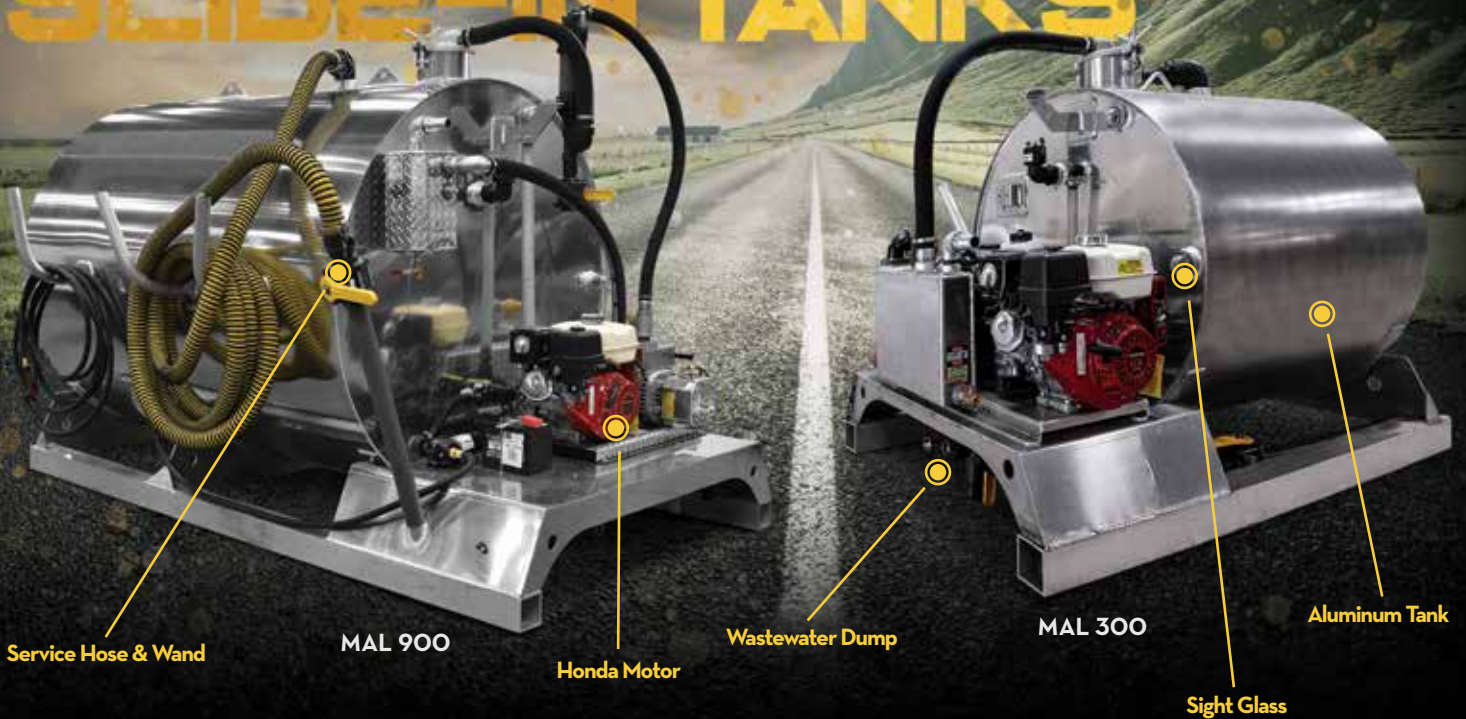

300 GALLONS TO 900 GALLONS

Not in the market for a truck? Consider one of Satellite Vacuum Truck's slide-in units instead. Available in three different materials, with three distinct pump systems, and sizes ranging from 300 to 900 gallons, you're sure to find a configuration that meets your needs. Each tank is meticulously crafted by Satellite's team of seasoned technicians, who prioritize the operator's comfort, resulting in the most ergonomically friendly design to reduce driver fatigue.

- CONTACT FOR CUSTOM BUILD AND SIZE
- ALL WASTE TANKS AVAILABLE

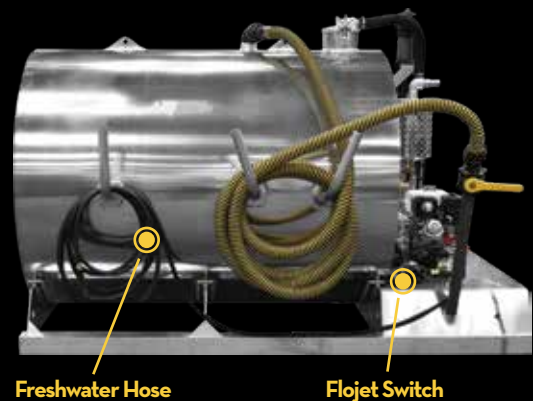



300 GALLON

Waste - 200 Gal | **Fresh** - 100 Gal

Material: Aluminum

Pumps: Conde, Masport, NVE

Width | Hanger: 48" | 55 11/16"

Height: 57 1/2" | **Length:** 72 1/8"



450 GALLON **ALUMINUM**

Waste - 300 Gal | **Fresh** - 150 Gal

Material: Aluminum

Pumps: Conde, Masport, NVE

Width | Hanger: 48" | 55 11/16"

Height: 57 1/2" | **Length:** 94 5/8"



450 GALLON **STAINLESS STEEL**

Waste - 300 Gal | **Fresh** - 150 Gal

Material: Stainless Steel

Pumps: Conde, Masport, NVE

Width | Hanger: 48" | 55 11/16"

Height: 57 1/2" | **Length:** 94 5/8"



550 GALLON

Waste - 370 Gal | **Fresh** - 180 Gal

Material: Aluminum

Pumps: Conde, Masport, NVE

Width | Hanger: 52" | 61 1/16"

Height: 64 3/8" | **Length:** 88 1/4"



650 GALLON

Waste - 430 Gal | **Fresh** - 220 Gal

Material: Aluminum,

Pumps: Conde, Masport, NVE

Width | Hanger: 52" | 61 1/16"

Height: 64 3/8" | **Length:** 101 1/4"



900 GALLON

Waste - 600 Gal | **Fresh** - 300 Gal

Material: Aluminum

Pumps: Conde, Masport, NVE

Width | Hanger: 59 1/2" | 69 1/4"

Height: 74.42" | **Length:** 108.19"

**All slide-in tanks can be offered in all waste options.*

SMALL EVENT

P&D 700

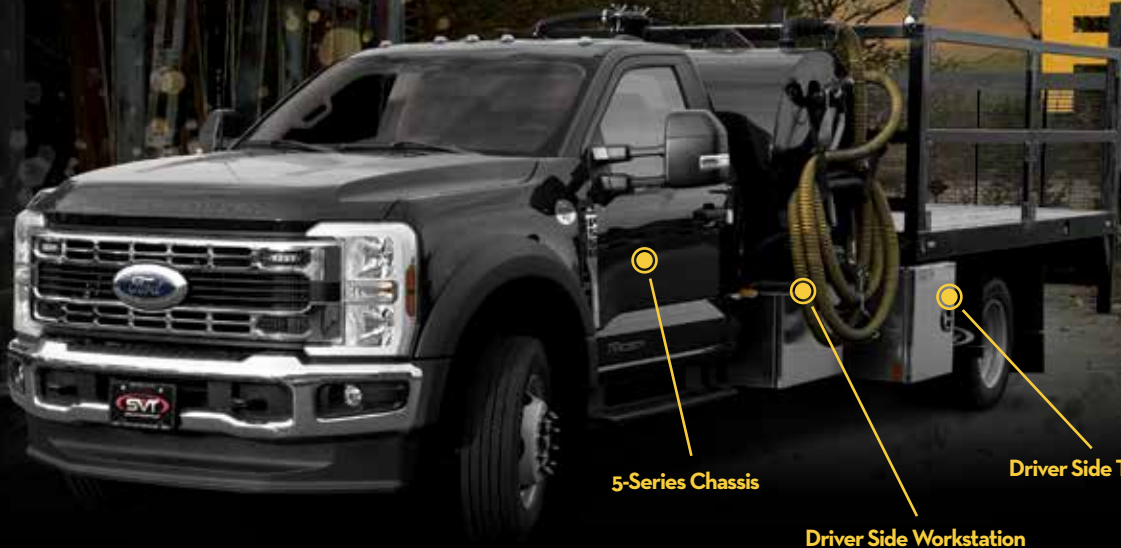

5-Series Chassis

Driver Side Workstation

Driver Side Toolbox

455-GALLON WASTE / 245-GALLON FRESH

Satellite Vacuum Trucks now offers the ultimate P&D truck for pulling trailers. The short-chassis P&D 700 is specifically designed for quick and efficient trailer positioning. Its tight turning radius and ergonomic design provide a clear view of the trailer while backing up, making it easy to spot and avoid obstacles that are often hidden when towing with standard service trucks.

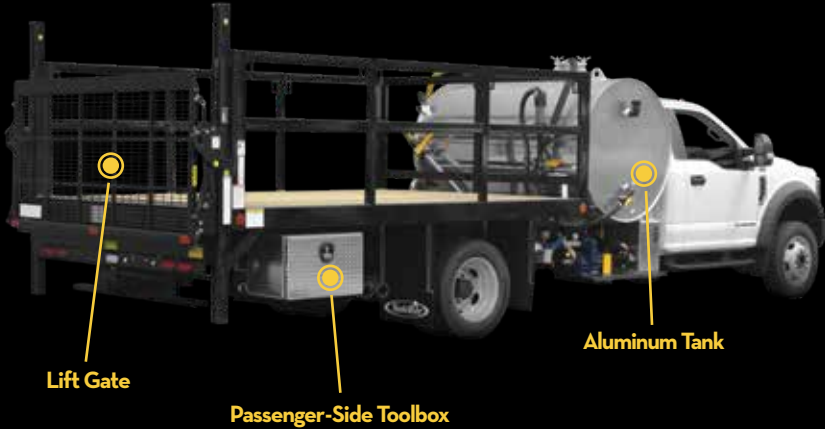

Lift Gate

Passenger-Side Toolbox

Aluminum Tank



■ PICK YOUR LENGTH



4ft 2-Unit

Recommended Bed for Hauling Trailers



8ft 4-Unit



12ft 6-Unit

* Unit numbers based on standard restroom size

HIGH-TRAFFIC RURAL ROUTES

P&D
900



Extendable Mirrors

Dump Valve

Driver Side Workstation

625-GALLON WASTE / 275-GALLON FRESH

If you're looking for a truck with attitude, then Satellite Vacuum Trucks P&D 900 is your perfect match! Designed with versatility in mind, Satellite's technicians have meticulously crafted every detail. The large backpack storage container ensures all your supplies are securely tucked away and protected from the elements. With a 900-gallon tank, you'll have ample space to service your entire route, and the truck's optional bed lengths make it possible to haul multiple units at once. The next time you're in the market for a truck, think P&D 900.

■ **1/4 TANK HEAD:** Ultimate in tank strength, longevity, ease of repair, and zinc anodes to help reduce corrosion.

■ **BACKPACK TOOLBOX (OPTIONAL):**

The Backpack Toolbox is an optional addition that consists of three large, open compartments and four doors. It allows Pumpers to safely store daily consumables and larger tools that wouldn't fit in an average toolbox.

■ **PICK YOUR LENGTH**



4ft 2-Unit
Recommended Bed
for Hauling Trailers



8ft 4-Unit



12ft 6-Unit

* Unit numbers based on standard restroom size

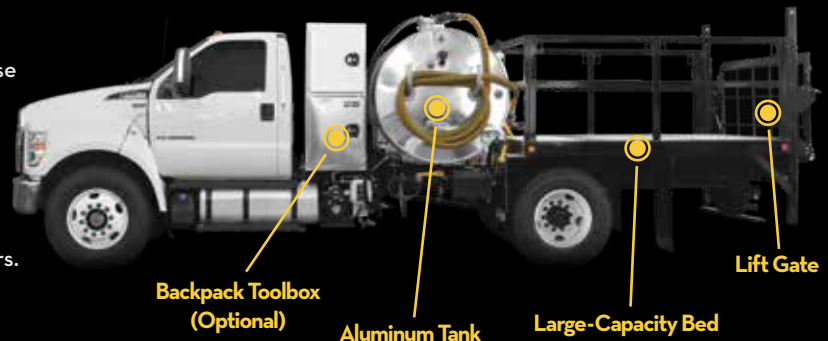

Backpack Toolbox
(Optional)

Aluminum Tank

Large-Capacity Bed

Lift Gate

HIGH TRAFFIC, LARGE EVENTS

P&D 1150



800-GALLON WASTE / 350-GALLON FRESH

Introducing the latest innovation from Satellite Vacuum Trucks – the P&D 1150. This newest addition to the Pick-up & Delivery line stands out with its unique design, featuring a separate flat freshwater tank below the truck bed and a large waste tank behind the cab. This combination maximizes hauling capacity and extends your daily route. Add the optional passenger-side workstation, and you have the perfect universal P&D truck, ready to tackle any job with ease and efficiency.

- **FRESHWATER TANK:** A flat 350-gallon freshwater tank is built into the truck bed to maximize every inch without reducing bed length.

■ PICK YOUR LENGTH



4ft 2-Unit
Recommended Bed
for Hauling Trailers



8ft 4-Unit



12ft 6-Unit * Unit numbers based on standard restroom size

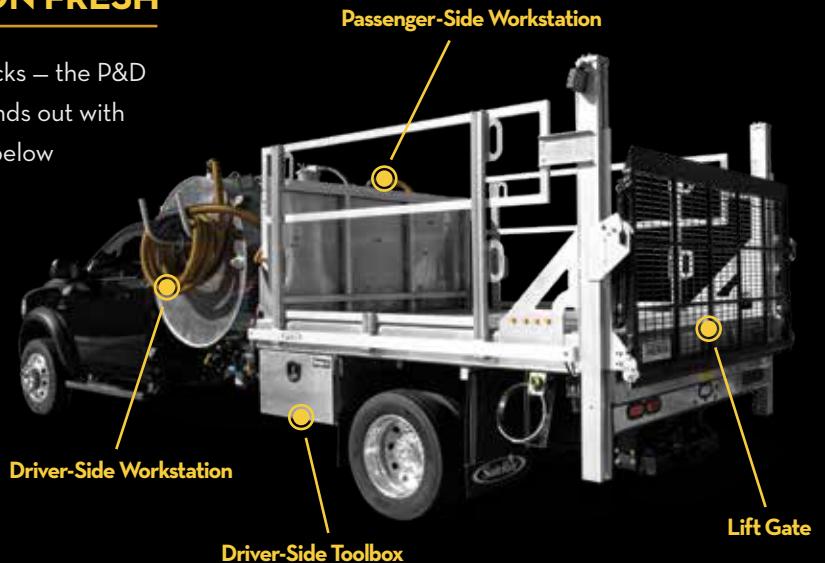

THE WORKHORSE

MD 950



650-GALLON WASTE / 300-GALLON FRESH

The MD 950 is the epitome of an ideal service truck. It offers a full range of customizable vacuum and washdown systems to perfectly match your specific needs. Key features include lowered cabinets for improved sight lines, increased workspace in the hose tray area, a reinforced unit hauler, and stainless-steel side and rear panels to prevent rusting. When you seek economy, comfort, reliability, safety, and enhanced performance, the MD 950 stands out as the ultimate choice.

- **TANK FINISH:** Diamond Vogel Epoxy powder-coated primer and polyester powder-coat to provide a durable high-gloss finish that will last for years.

■ SS OPTIONS AVAILABLE

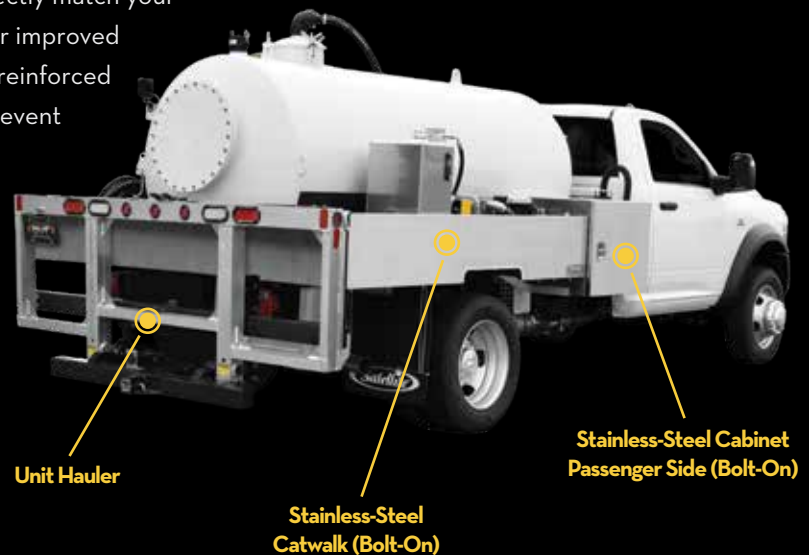

HIGH-DENSITY ROUTES

MD 995



695-GALLON WASTE / 300-GALLON FRESH

The MD 995 Flat Vac is perfect for those needing extra capacity for hauling restrooms. It can accommodate eight standard units and features a 695-gallon waste tank along with a 300-gallon freshwater tank, making daily routes more efficient. Additionally, its ergonomic design, including a lowered service area and easily accessible stainless-steel cabinets, enhances driver efficiency and reduces fatigue throughout the day.

- **TANK FINISH:** Primed and painted to provide a durable high-gloss finish that will last for years.

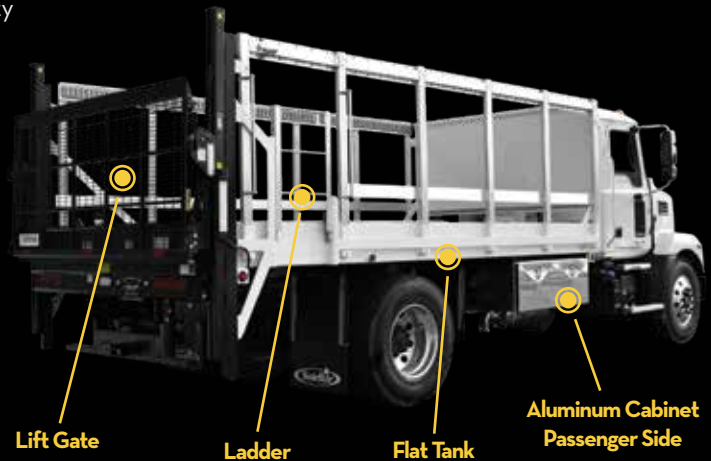

SAME FOOTPRINT, LARGER PAYLOAD

MD 1250



Stainless-Steel Cabinet
Driver Side (Bolt-On)

Lowered Workstation
Driver Side

Freshwater
Basket

850-GALLON WASTE / 400-GALLON FRESH

The MD 1250 is a versatile, medium-sized vehicle expertly crafted to navigate even the tightest spaces with ease. Featuring an 850-gallon waste tank and a 400-gallon freshwater tank, it has the capacity to handle most routes efficiently. Designed with the driver in mind, it boasts a lowered workstation that makes servicing effortless, even for smaller-stature drivers. If you're in the market for a new pump truck, the new F-600 chassis is an exceptional choice. Its heavier GVWR allows Satellite to equip it with a 1250-gallon tank, all while maintaining the same compact footprint as the F-550.

■ **GALVANIZED-STEEL UNIT HAULER:** This feature provides safe and secure points for transporting standard portable toilets, reducing effort for loading and unloading.

■ **CHEVY, INTERNATIONAL CV, F-600**

■ **SS OPTIONS AVAILABLE**

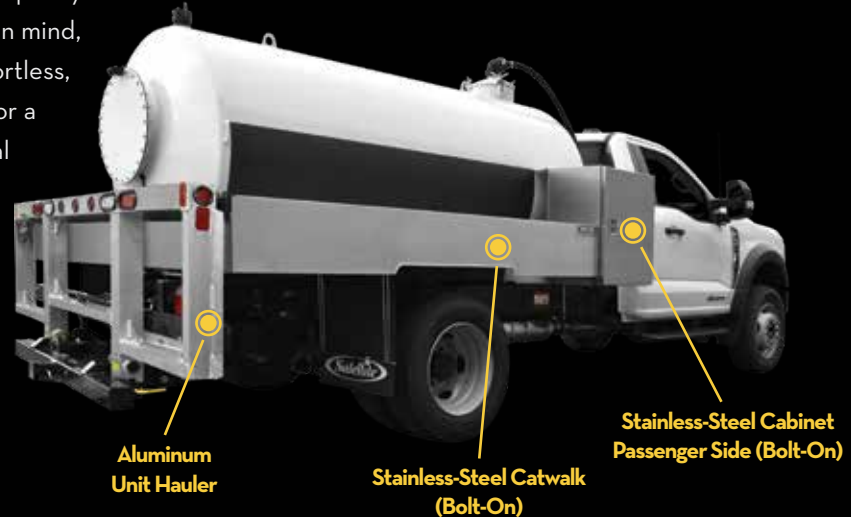

Aluminum
Unit Hauler

Stainless-Steel Catwalk
(Bolt-On)

Stainless-Steel Cabinet
Passenger Side (Bolt-On)

HIGH-DENSITY CITY ROUTES

MD 1600



1100-GALLON WASTE / 500-GALLON FRESH

The MD 1600 is perfectly sized for high-density city routes. It features large dual cabinets that offer ample storage, and a lowered workstation that provides an efficient ergonomic service area, even for smaller-stature drivers. A full range of vacuum and washdown systems can be custom-tailored to fit your specific application. Additionally, the tank's unique baffle design enhances stability during sudden turns or stops.

- **COATED FRESH COMPARTMENT:** This provides clean, clear water with manway and round sight glasses to measure tank levels. Internal safety baffle included.





1100-GALLON WASTE / 500-GALLON FRESH

The SS 1600 is built for busy city routes. Compact and maneuverable, it features a rugged stainless-steel tank designed to outlast all other materials, no rust, corrosion, repainting, or interior coating required.

Oversized dual cabinets provide ample storage, while a lowered workstation delivers an efficient, ergonomic service area for drivers of all statures. The SS 1600 can be customized with a full range of vacuum and washdown systems, and its advanced baffle design improves stability during sharp turns and sudden stops.

Durable, efficient, and built to last, the SS 1600 is the smart choice for demanding urban routes.

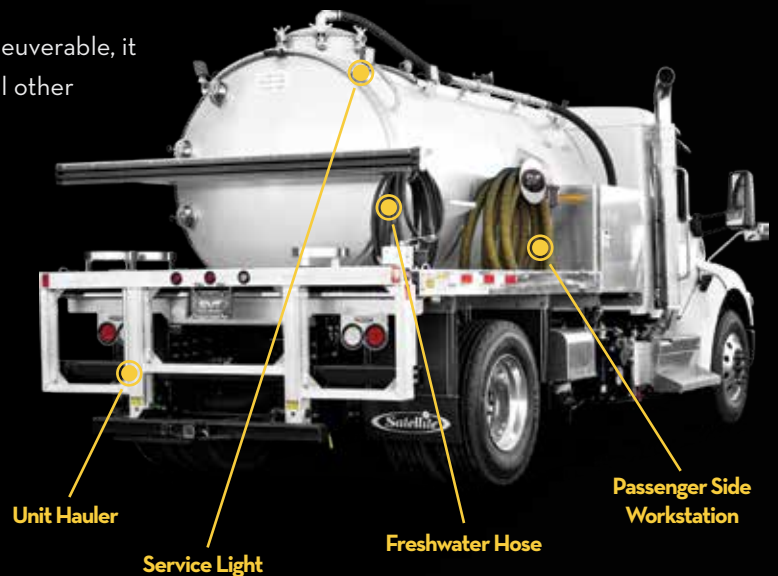

VERSATILE AND LIGHT WEIGHT

MAL 1300



- Service Light
- Aluminum Cabinet Driver Side
- Lowered Workstation

900-GALLON WASTE / 400-GALLON FRESH

The MAL 1300 is your perfect companion for high-density routes needing exceptional maneuverability and frequent daily services. Crafted with lightweight 5454 aluminum, it boasts a robust chassis and an 84-inch cab-to-axle configuration, blending the agility of a pick-up with the capacity of a full-sized service truck. Dual low-profile cabinets offer ample storage, while the ergonomically lowered workstation ensures comfort and efficiency, even for shorter drivers. Plus, you can customize various vacuum and washdown systems to fit your specific needs.

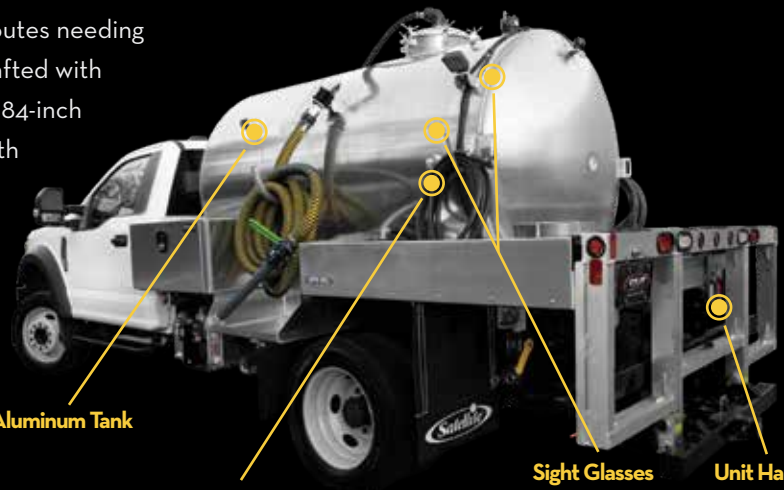

- Aluminum Tank
- Freshwater Hose
- Sight Glasses
- Unit Hauler

DEMANDING, HIGH-CAPACITY ROUTES

MAL 2150

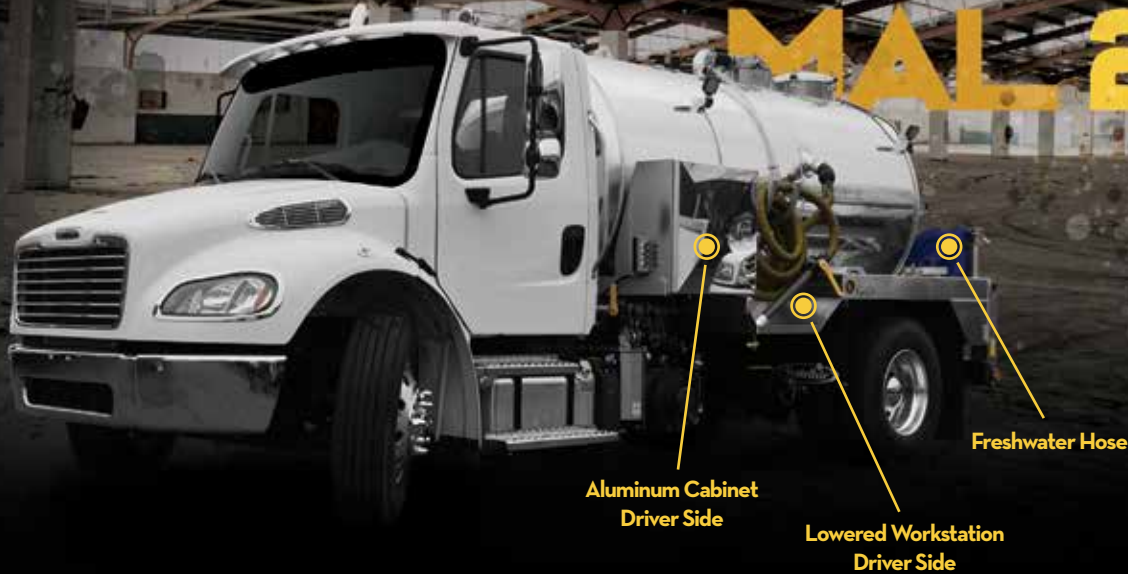

1600-GALLON WASTE / 550-GALLON FRESH

The MAL 2150 is engineered for demanding, high-capacity routes. Featuring lightweight ASTM 5454 aluminum construction and a 25,999 GVW or heavier chassis, it boasts a remarkable 1600-gallon waste capacity and 550-gallon freshwater capacity. Large dual cabinets offer ample storage, while the lowered workstation ensures an efficient, ergonomic service area, even for smaller-stature drivers. Customize a variety of vacuum and washdown systems to fit your specific application.

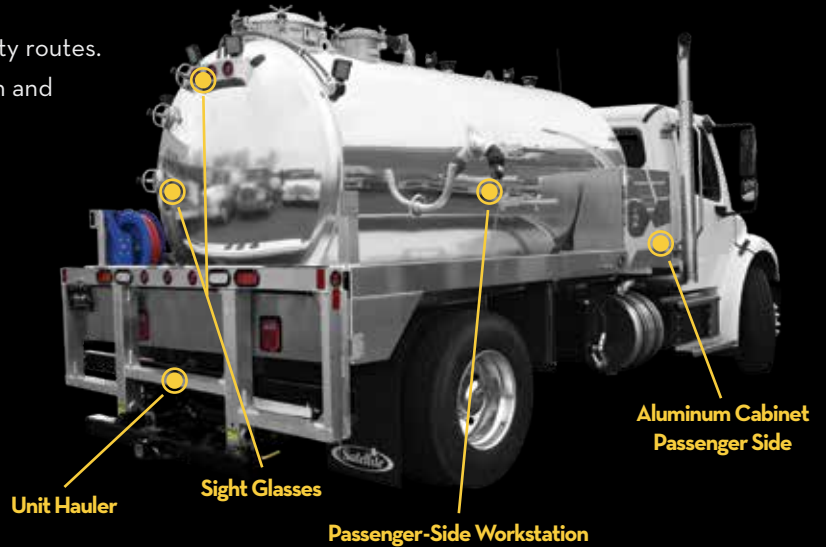

IDEAL FOR MANEUVERING AROUND TIGHT SPOTS

CABOVER TRUCKS

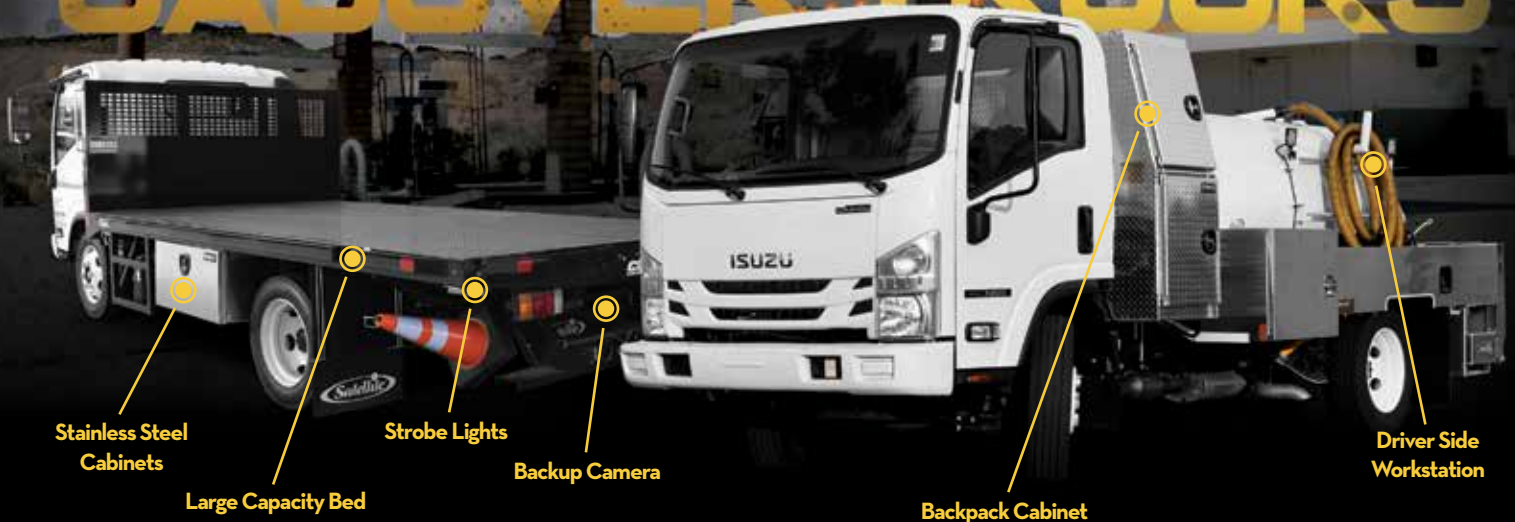

EXTREME VERSATILITY

When versatility is paramount, turn to the Satellite's Cabover line. Featuring the Isuzu NRR chassis, it offers a best-in-class turning radius to handle various configurations seamlessly.

The low cab forward design enhances driver visibility, allowing obstacles to be seen directly in front. This makes it perfect for maneuvering tight urban spots and trailer positioning. Its compact cab design also maximizes hauling space.

Available in both gas and diesel, the chassis offers versatile configurations to meet various needs, from fence trucks to P&D. This ensures it's both operator and route-friendly. Plus, the tank is available in lightweight aluminum, mild steel, or stainless steel, providing unmatched flexibility in designing your truck.



ISUZU FENCE TRUCK

Satellite's Fence Truck sets the standard for efficiency and visibility. With an 8x12' bed, two stainless steel cabinets for ample storage, a built-in step ladder for easy access, and strobe lights on all sides, it's perfect for any work zone.

Bed Length - 12' | Bed Width - 8' | GVW: 19,500 lbs

Material: Aluminum, Carbon Steel, Stainless Steel



ISUZU MD 950

The Isuzu MD 950 is ideal for urban environments. It features customizable vacuum and washdown systems, ensuring ergonomic design and efficiency to meet your specific needs. This truck combines maneuverability with tailored functionality, making it perfect for city operations.

Waste - 650 Gal | **Fresh** - 300 Gal | **GVW:** 19,500 lbs

Material: Carbon Steel, Stainless Steel

ISUZU MAL 1300

The Isuzu MAL 1300 is designed for high-density routes requiring exceptional maneuverability and frequent services. Its lightweight aluminum construction and cabover chassis offer the agility of a pick-up truck with the capacity of a large service vehicle, ensuring easy navigation and efficient handling of high service volumes.

Waste - 900 Gal | **Fresh** - 400 Gal | **GVW:** 19,500 lbs

Material: Aluminum



ISUZU P&D 700

The Isuzu P&D 700 is the ultimate urban service truck with an exceptional tight turning radius. It offers customizable vacuum and washdown systems, ensuring ergonomic design for maximum efficiency and comfort. Build a truck that fits your application and enhances productivity.

Waste - 455 Gal | **Fresh** - 245 Gal | **GVW:** 19,500 lbs

Material: Aluminum



BIG TANK, LIGHTWEIGHT CHASSIS

SINGLE AXLE



2000-GALLON WASTE TO 2500-GALLON WASTE

Satellite Vacuum Trucks offers a diverse range of high-quality single-axle vacuum trucks that are both cost-effective and exempt from the extra FET tax required for trucks over 33,001 lbs. These highly maneuverable trucks feature tanks ranging from 2,000 to 2,500 gallons and are available in aluminum, stainless steel, and steel. Designed for versatility, Satellite Vacuum Trucks are built to excel in any field that requires reliable vacuum truck services.

- THIRD AXLE AVAILABLE
- WATER COMBO SPLITS AVAILABLE
- JETTER SYSTEMS AVAILABLE

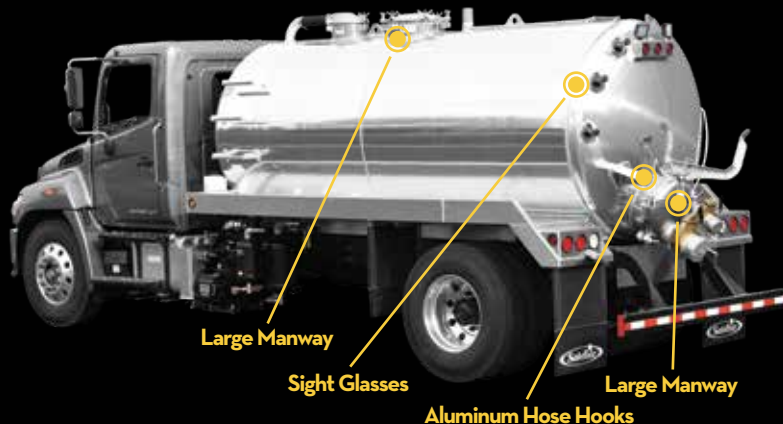

CONQUER EVEN THE BIGGEST JOBS

TANDEM AXLE



3000-GALLON WASTE TO 5000-GALLON WASTE

For your larger tasks, Satellite Vacuum Truck's tandem-axle truck is an unbeatable choice. With tank sizes ranging from 3,000 to 5,000 gallons, these trucks are built to tackle even the most demanding jobs. You can customize your truck with features like tilt beds, code trucks, and hitches to suit your specific needs. Just like its smaller counterpart, the tandem-axle truck is available in aluminum, stainless steel, and steel tanks, ensuring durability and versatility for any application.

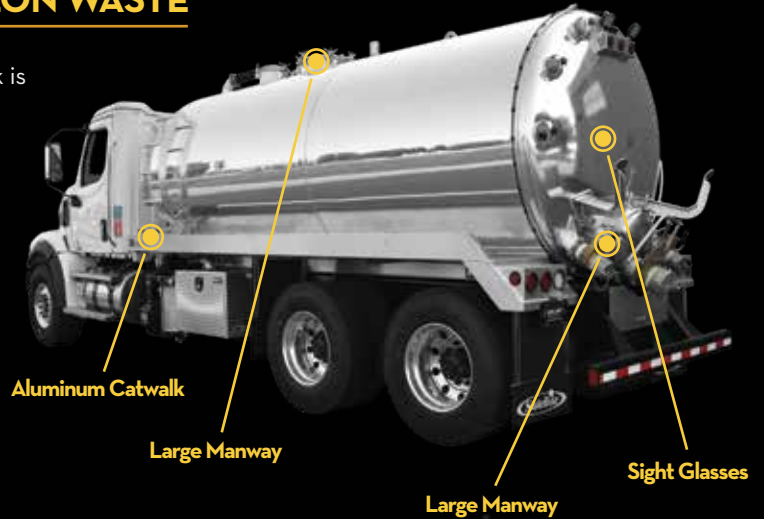

POLISHED AND PROFESSIONAL

ACCESSORIES



PATHFINDER

The Pathfinder is a cutting-edge sanitizing system that easily mounts to any service vehicle. Its unique low-pressure chemical injection delivery system ensures the perfect chemical-to-water mix for maximum effectiveness. This allows you to evenly spray a cleaning agent like Pathfinder Solution or a hospital-grade, EPA-registered disinfectant throughout the restroom.

This advanced system reduces mold and odor-causing bacteria by an impressive 86% compared to traditional cleaning methods. Unlike the old scrub-brush-and-soap approach, our system prevents the transfer of bacteria and germs from one unit to another. Everyone will appreciate the fresh, clean appearance of your restroom, knowing it has been thoroughly sanitized with each service.





HOSE REEL

Always keep your hose ready to go with our hose reel. Effortless storage and smooth unwinding make every task a breeze.



TRUCK WASH

Heavy-duty Truck Wash removes road film, grease and deposits. Keeps trucks and trailers looking like new.



SUCTION HOSE

The 3" x 30' suction hose is built for high performance and durability, ensuring reliable suction power every time!



SAFETY CONES

Stay safe and visible with our durable, high-visibility safety cones. Ideal for traffic control and job site safety.



HIGH-PRESSURE WASH

Blast away tough dirt effortlessly with our high-pressure washdown system, ensuring a fast and thorough clean. Achieve spotless results with minimal effort!



BACK-UP CAMERA

Boost your visibility and safety with our rear dual back-up cameras. Enjoy a wide-angle view that makes every drive and maneuver seamless and worry-free!



CONE HOLDER

Experience the ultimate convenience with Satellite's Cone Holder. Your cones are always ready and within reach whenever you need them.



WHEEL CHOKES

Confidently secure your vehicle with our heavy-duty wheel chocks, designed for maximum stability.